

**5R18:
ENVIRONMENTAL FLUID MECHANICS AND AIR POLLUTION**

Dispersion of Pollution in the Atmospheric Environment

“Air and water, the two essential fluids on which all life depends, have become global garbage cans”

“Mankind has probably done more damage to the Earth in the 20th century than in all of previous human history”

(Jacques Yves Cousteau, 1910-1997)

**Prof. E. Mastorakos
Hopkinson Lab
Tel: 32690
E-mail: em257@eng.cam.ac.uk**

Table of Contents

1. Introduction
2. Atmospheric structure, chemistry and pollution
3. Statistical description of turbulent mixing and reaction
4. Air Quality Modelling and Plume Dispersion
5. Turbulent reacting flows and stochastic simulations
6. Summary and main points

1. Introduction

1.1 The problem

About 90% of the world's energy comes from fossil fuels. Energy is needed for transport (land, sea, air), electricity generation, heating in buildings and industrial processes (e.g. iron, steel, aluminium, paper, cement manufacture). Combustion occurs in boilers, refineries, glass melters, drying kilns, incinerators, industrial ovens and is also used to generate energy from biomass (e.g. from wood, straw, organic waste). Burning fossil fuels, however, may result in *environmental pollution*. There are many other sources of air pollution. The chemical industry (e.g. hydrocarbon vapours, freon, sulphur oxides), metallurgy (particulates), refineries, and even the domestic environment (e.g. particles from cooking, solvents in paint and varnishes) are just a few. Apart from emissions in the air, we also have pollution of the aqueous environment (sea, lakes, rivers) from industrial discharges, municipal waste (e.g. in landfills) and oil spills. The amount of pollutants emitted from all sources is *strictly regulated* by legislation in most of the developed world and forms the topic of political discussion and affects economic decisions. More pollutants are added to the list every year and their effects on human health come under increasing scrutiny.

In most environmental pollution problems, the pollutant is released to the environment by the, almost always, *turbulent* flow of a carrier fluid. The pollutant mixes with the surrounding fluid (air or water) and undergoes chemical transformations. A proper account of “*where the pollutant went*” and “*what happened to it*” necessitates a theory of *turbulent reacting flows*, i.e. the simultaneous treatment of *mixing* and *chemical reactions*.

Due to the complexity of this topic, in this course we will discuss a little of turbulent mixing, a little of atmospheric pollution reactions, and we will just touch on how the two phenomena may be treated together. In doing so, we will also touch on the extremely important field of Air Quality Modelling, which is an interdisciplinary field borrowing elements from Fluid Mechanics, Atmospheric Chemistry, Meteorology and others.

1.2 Objectives

The objectives of this series of lectures are:

- To present the nature of atmospheric pollution.
- To present commonly used pollutant dispersion models.
- To make the student familiar with the topic of Air Quality Modelling.
- To introduce the necessity to study turbulent reacting flows.
- To introduce techniques for simulating turbulent reacting flows.

At the end of the lectures, the student should:

- Be able to make simple estimates of the amounts of pollutant reaching a given point far away from a pollution source.
- Understand how the local meteorology may affect pollutant dispersion.
- Understand some of the physics of turbulent mixing.
- Be able to estimate how the turbulence may affect the rate of pollutant transformation.
- Be familiar with techniques and software used in practical Air Quality Modelling.
- Be able to design a Monte-Carlo simulation for stochastic phenomena.

1.3 Structure of this course

These lecture notes are organized as follows: elements of chemical kinetics, the nature of atmospheric pollutants and a little atmospheric chemistry are discussed in Chapter 2. In Chapter 3, a description of the fundamentals of turbulent mixing is given. In Chapter 4, the model problem of dispersion of a chimney plume is discussed in detail. Chapter 5 presents some usual theories for turbulent reacting flows and emphasizes the use of Monte Carlo techniques to overcome the closure problems introduced by the turbulence. Although it is not crucial, we will be mostly considering gaseous flows.

Simple computational codes of the type used in Air Quality Modelling for decision-making will be demonstrated and the assumptions behind them will be fully discussed.

1.4 Bibliography

Csanady, G. T. (1973) Turbulent Diffusion in the Environment. Reidel Publishing Company.

Chapter 3 is one of the classics in the field of turbulent mixing and goes deep in the physics involved and describes well the applications. Very useful for our Chapter 4.

De Nevers, N. (1995) Air Pollution Control Engineering. McGraw Hill.

Discusses various features of air pollution engineering (pollution control techniques, NO_x chemistry, plume dispersion). Very useful for Chapters 2 and 4 of this course. Highly recommended and a very good addition to any engineer's library.

Jacobson, M. Z. (1999) Fundamentals of Atmospheric Modelling. Cambridge University Press.

Discusses various features of air pollution and the current generation of atmospheric dispersion codes. Chapter 11 (pp. 298-307) is very useful for the various harmful effects of air pollution and the species that participate in smog formation and Ch. 2 (pp. 6-20) for the atmospheric structure. For those who like chemistry and who want to follow Air Quality Modelling as a profession.

Pope, S.B. (2000) Turbulent Flows. Cambridge University Press.

Not for the faint-hearted! Chapter 3 describes in detail the pdf approach of turbulence, while Chapter 12 gives the full Monte Carlo treatment for turbulent flows. PhD level.

Tennekes and Lumley (1972) An Introduction to Turbulence. MIT Press.

Chapter 1 from this book is one of the best introductions to turbulence available and you should read it. Chapter 6 gives the probabilistic description of turbulence. Both chapters are recommended, but you may avoid the difficult mathematical bits of chapter 6.

2. Atmospheric structure, chemistry and pollution

In this Chapter, we will give a quick revision of terms and concepts from chemical kinetics, which are needed to allow us to use and understand atmospheric chemistry. Some particular features of pollution chemistry then follow and information on the structure of the atmosphere is given.

2.1 Fundamental concepts – revision of chemistry

Mole and mass fractions, concentrations

Assume that pollutant A reacts with species B, which could be another pollutant or a background species (e.g. N₂, O₂, H₂O in the air). The reaction rate depends on the amount of reactant present. There are many ways to quantify the amount of a species in a mixture: concentration, mole (or volume) and mass fractions are the most usual. The ratio of the number of kmols, n_i , of a particular species i to the total number of kmols n_{tot} in the mixture is the *mole fraction* or *volume fraction*:

$$X_i = \frac{n_i}{n_{tot}}. \quad (2.1)$$

The *mass fraction* Y_i is defined as the mass of i divided by the total mass. Using the obvious

$$\sum_{i=1}^N X_i = \sum_{i=1}^N Y_i = 1, \quad (2.2)$$

where N is the total number of species in our mixture, the following can be easily derived for Y_i and the mixture molecular weight \overline{MW} :

$$Y_i = X_i \frac{MW_i}{\overline{MW}}, \quad (2.3)$$

$$\overline{MW} = \sum_{i=1}^N X_i MW_i = \left(\sum_{i=1}^N \frac{Y_i}{MW_i} \right)^{-1}. \quad (2.4)$$

Virtually always, the mixture molecular weight will be very close to that of air since the pollutant is dilute (i.e. even if it is heavy, its contribution to the weight of a kmol of mixture is very small). Equation (2.4) is included here only for completeness.

The *concentration* (or molar concentration) of species i is defined as the number of kmols of the species per unit volume. The usual notation used for concentrations is C_i or the chemical symbol of the species in square brackets, e.g. [NO] for nitric oxide, or [A] for our generic pollutant A. From this definition and Eq. (2.1),

$$C_i = \frac{n_i}{V} = \frac{X_i n_{tot}}{V}, \quad (2.5)$$

and using the equation of state $PV = n_{tot} R^0 T$ (R^0 is the universal gas constant), we get:

$$C_i = \frac{X_i n_{tot}}{n_{tot} R^0 T / P} = X_i \frac{P}{R^0 T} \quad (2.6)$$

This relates the concentration to the mole fraction. In most atmospheric pollution problems, the concentrations are quoted in *molecules/m³* or *kmol/m³* and the volume fractions in *parts per billion* (ppb). A very common unit is *kg of pollutant per m³ of air*, which is the molar concentration times the molecular weight of the species. We can also relate the concentration to the mass fraction:

$$C_i = \frac{Y_i \overline{MW}}{MW_i} \frac{P}{R^0 T} = \frac{Y_i \rho}{MW_i} \quad (2.7)$$

where ρ is the mixture density, e.g. the air density for our problems. Usually, the chemical reaction rate is expressed in terms of molar concentrations, while the conservation laws for mass and energy are expressed in terms of mass fractions. On the other hand, pollution monitoring equipment measures usually the volume fractions or the *kg/m³* of the pollutant. The above relations are useful for performing transformations between the various quantities, which is very often needed in practice.

Global and elementary reactions

Chemical reactions occur when molecules of one species collide with molecules of another species and, for some of these collisions, one or more new molecules will be created. The chemical reaction essentially involves a re-distribution of how atoms are bonded together in the molecule. To achieve this, chemical bonds must be broken during the impact (i.e. the molecules must have sufficient kinetic energy) and other bonds must be formed. As the energy of these bonds depends on the nature of the atoms and on geometrical factors, the energy content of the products of the collision may be different from the energy content of the colliding molecules. This is the origin of the heat released (or absorbed) in chemical reactions.

We write often that, for example, methane is oxidised according to $\text{CH}_4 + 2\text{O}_2 \rightarrow \text{CO}_2 + 2\text{H}_2\text{O}$. This is an example of a *global reaction*. What we mean is that the overall process of oxidation uses 1 kmol of CH_4 and 2 kmol of O_2 to produce, if complete, 1 kmol of CO_2 and 2 kmol of H_2O . We do not mean that all this occurs during an actual molecular collision. This would be impossible to happen because it would involve too many bonds to break and too many bonds to form. However, the reactions

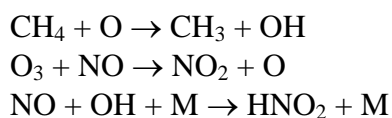

are possible. For example, the first of these involves breaking one C-H bond and forming a O-H one. These reactions are examples of *elementary reactions*, i.e. reactions that can occur during a molecular collision. The overall chemical transformation follows hundreds or thousands of such elementary reactions and many species and *radicals* appear. By the term “radicals” we mean very reactive unstable molecules like O, H, OH, or CH_3 . The series of elementary reactions that describes the overall process is called a *reaction mechanism* or *detailed chemical mechanism*. Most chemical transformations occur following reaction mechanisms, rather than single reactions.

The concept of global reaction helps us visualize the overall process and stoichiometry in an engineering sense. But when we identify the elementary reactions we can talk in detail about what really happens.

The Law of Mass Action

A large part of the science of Chemical Kinetics is centred on identifying which elementary reactions are possible under various conditions for various species and to prescribe the *rate*, i.e. how quickly these reactions take place. This is given by the Law of Mass Action. Consider the generic elementary reaction

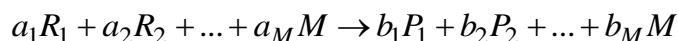

between reactants R_1, R_2, R_3, \dots , from which products P_1, P_2, P_3, \dots , are formed. M is an example of species that appears on both sides. The rates of reactants consumption and products formation and the *reaction rate* are given by:

$$\frac{d[R_1]}{dt} = -a_1\omega, \quad \frac{d[R_2]}{dt} = -a_2\omega, \quad \dots \quad \frac{d[P_1]}{dt} = b_1\omega, \quad \frac{d[P_2]}{dt} = b_2\omega, \quad \dots$$

$$\frac{d[M]}{dt} = b_M\omega - a_M\omega \tag{2.8}$$

$$\omega = k[R_1]^{a_1}[R_2]^{a_2}[R_3]^{a_3} \dots \tag{2.9}$$

The parameter k is the *reaction rate constant* and $[R_1]$ is the concentration (in kmol/m^3) of reactant R_1 etc. Equation (2.8) is a statement of the *stoichiometry* of the reaction: every a_1 kmol of R_1 is joined by a_2 kmol of R_2 , etc., to produce simultaneously b_1 kmol of P_1 , b_2 kmol of P_2 , etc.. If $b_M = a_M$, then M is called a *third body*: it may not be altered, but its presence is crucial for the success of the reaction, as it provides energy to, or takes energy away from, the collision between the reactants. Equation (2.9) is the *Law of Mass Action* and states that the reaction rate is proportional to the reactants concentrations, raised to their respective *stoichiometric coefficients* (i.e. a_1, a_2 , etc). The amount of products does not affect ω . The reaction rate constant k is not a function of the reactants concentration and it is specific to the elementary reaction.

Sometimes, Eq. (2.9) is used for a global reaction as an approximation. In that case, the reaction rate constant and the indices a_1, a_2 , etc. are determined empirically.

The reaction rate constant

The reaction rate constant is given by the *Arrhenius law*:

$$k = A \exp\left(-\frac{E_{act}}{R^0 T}\right) \tag{2.10}$$

where A is the *pre-exponential factor* and E_{act} is the *activation energy*. These quantities come from experiment or statistical mechanics calculations. Out of all molecular collisions, only those with kinetic energy higher than the energy needed to break bonds inside the reactants' molecules will result in reaction. The proportion of these collisions is given by $\exp(-E_{act}/R^0 T)$ (from Kinetic Theory of Gases). The reaction rate constant *increases very fast with temperature*.

In many environmental pollution problems, the flows are isothermal or the temperature changes little, so the reaction rate constant may be taken as uniform in space. However, the temperature may change significantly during the day so that large changes in reaction rates can be observed between noon and midnight.

2.2 Pollutants and their sources

An overview

The total emissions of the major *regulated* pollutants (i.e. controlled by legislation) have been categorized according to sectors of economic activity in Table 2.1, with the percentage contribution of each sector being typical for all industrialized countries. As we can see, transportation and electricity generation are the activities that make the highest contribution for almost all pollutants, apart from VOC's, which are mostly emitted by industrial processes. More information and explanations for each of these pollutants, including some not shown in Table 2.1, is given next.

Obviously, with the development of clean or pollution-abating technologies the total emission of these is decreasing, but with increasing economic activity they may be increasing. Also, each country may have very different emission inventories.

Table 2.1. Estimates of the US emissions of the major regulated pollutants for 1991 (million tons per year) per category of source. (From de Nevers, 1995).

Source category	CO	SO _x	NO _x	PM ₁₀	VOC
Transportation	43.49	0.99	7.26	1.51	5.08
Electricity generation	4.67	16.55	10.59	1.10	0.67
Industrial processes	4.69	3.16	0.60	1.84	7.86
Solid waste disposal	3.06	0.02	0.10	0.26	0.69
Miscellaneous	7.18	0.01	0.21	0.73	2.59
Total	62.09	20.73	18.76	5.44	16.89

Fuel contributions

When we burn fuels, we have to deal with the impurities they may *already* contain, but also with pollutants that may be generated during combustion, for example nitric oxides (NO_x) and soot. *Clean fuels* like natural gas, propane, and good-quality gasoline do not contain impurities. In contrast, some fuels contain substances that, either directly or in modified form after passing through the combustion process, may cause harm when released. For example some heavy oils and diesels may contain *sulphur* and traces of *metals*, while various fuel-like substances used in incinerators (e.g. car tyres, plastics, municipal waste, hazardous wastes) may release hundreds of toxic substances if burned in the wrong way. Hence fuel-switching is an obvious method to reduce the amount of a particular pollutant emitted (e.g. from sulphur-containing coal to natural gas). Of course, this may lead to the emission of more of another pollutant.

Carbon dioxide

All the carbon in the fuel will eventually be transformed to carbon dioxide in the atmosphere. Another important source of carbon dioxide is cement manufacture. Carbon dioxide is a major contributor to the *greenhouse effect*, which is a term denoting the warming of the atmosphere due to the CO₂ absorbing part of the radiation emitted by the earth surface. This may then lead to *global warming*. Using fossil fuels will invariably lead to CO₂ production and hence, at the very least, we should make sure we burn fuels as efficiently as possible. Power generation is an

important player in the public debate concerning global climate change. Switching to renewable energies alleviates the danger of global warming.

Carbon monoxide

Incomplete combustion results in CO formation. Carbon monoxide is extremely dangerous and can cause death if inhaled in large concentrations because it inhibits the acquisition of oxygen in our blood stream. It is mostly emitted by cars (Table 2.1). The use of *catalysts* has helped to reduce the problem considerably by ensuring the oxidation of CO to CO₂. The trail of CO behind a car is of interest to environmental regulation agencies and methods to predict and measure CO are being developed.

Sulphur oxides

When burning fuels with sulphur, like coal and diesel, all of the sulphur will be oxidised into SO₂ and SO₃, collectively called SO_x. Other sources are processes like copper smelting. Sulphur oxides pose serious problems because: (i) SO_x dissolves in clouds to form sulphuric acid, which can then be deposited to the earth by rain. This is called “acid rain” and has caused deforestation in Europe and North America and serious damage to structures (monuments, steel buildings). (ii) SO_x is a respiratory irritant and in large concentrations can cause death. Sulphur-rich coal combustion for domestic use (e.g. for cooking or heating) has been responsible for thousands of deaths in London over the past centuries, notably during the “Great London Smog” in December 1952, in which about 4,000 people died.

Current emission standards on sulphur oxide emissions are very strict and are met by post-combustion treatment of the exhaust gases. This is based mostly on *scrubbing*: mixing the exhaust gases with water droplets that contain limestone, which reacts with the oxide according to $\text{CaCO}_3 + \text{SO}_2 + 0.5\text{O}_2 \rightarrow \text{CaSO}_4 + \text{CO}_2$. The cost of the scrubbers is a very large percentage of a modern coal power station.

Nitrogen oxides

Two of the most serious pollutants attributed to fossil fuel usage are nitric oxide (NO) and nitrogen dioxide (NO₂), collectively called NO_x. Usually, only NO is emitted, but this will react in the atmosphere to create NO₂ (Section 2.3). Other sources of nitric oxides in the atmosphere include agriculture (fertilizer production). Nitrogen oxides will form acid rain, by a similar mechanism to SO_x. At ground level and under sunlight, NO₂ will release an oxygen atom that can then form ozone (O₃) (more of this later). Ozone is very irritating for the respiratory system and causes impaired vision. In addition, NO emitted by high-altitude airplanes participates in ozone destruction and hence contributes to the ozone hole problem. Nitrogen oxides are strictly regulated and low-NO_x combustion equipment (burners, processes, cars, domestic heaters) has become today a huge business.

Particulate matter and soot

Combustion without excess air may lead to soot formation. By “soot” we mean solid particles of size less than 1µm, which result in the yellow colour of flames and in the smoke emitted from diesel engines and some older gas turbines. The particulate matter may cause lung diseases and is hence controlled by legislation. The particulates are usually denoted by PM₁₀, which means “particulate matter of size less than 10µm”. Other anthropogenic sources of PM₁₀ in the atmosphere

include ash particles from coal power stations, while natural sources are salt particles from breaking sea waves, pollen, dust, forest fires, and volcanic eruptions.

VOC

The term VOC refers to “volatile organic compounds”. By VOC we mean evaporated gasoline from petrol filling stations, vapours from refineries, organic solvents from paint and dry cleaning, and many others. These organic species are major contributors to smog and may be toxic or carcinogenic for humans. Their emissions are strictly regulated. Studies have found that glues and paints in our houses may have serious adverse health effects. There is a large effort today to switch to water-based paint, so that emissions of VOC’s are decreased.

Heavy metals and dioxins

If metals are contained in the reactants to our process (e.g. burner, kiln, chemical reactor), they may end up in the atmosphere (in pure form or in oxides) and they could be very dangerous (particularly Hg, Cd, Pb, As, Be, Cr, and Sb). This is a serious problem for municipal, toxic, and hospital waste incinerators. If the fuel contains chlorine, for example if it includes plastics (PVC), then there is a danger that *dioxins* may be formed – not at the flame, but on medium-temperature metal surfaces in the stack or inside the waste itself. Dioxins are chlorinated aromatic organic compounds whose chemistry is not very well known. They are extremely dangerous because they are carcinogenic even in concentrations of part per trillion. Municipal waste incinerators are needed to decrease the volume of waste going to landfills and to generate some power, but their use is controversial because of the danger of dioxins. If the plant operates at the design point, the exhaust is probably free of dangerous substances because a lot of attention has been given to the clean-up stage. However, open, uncontrolled burning of any waste or plastic material is extremely dangerous. Other sources of dioxins used to be the paper industry, where chlorine-containing compounds were used for bleaching the pulp and ended up in the waste stream of the paper mill, but this problem seems to have improved considerably with the introduction of new chlorine-free techniques.

2.3 Some chemistry of atmospheric pollution

Smog formation

One of the most important environmental problems is smog formation (Smoke + Fog), also called *photochemical pollution*. This is the brown colour we sometimes see above polluted cities and consists of a very large number of chemicals, but the most important are nitric oxide (NO), nitrogen dioxide (NO₂), ozone (O₃), and hydrocarbons (VOC). Some of the reactions participating in smog formation are discussed below.

Oxidation of NO to NO₂

Of the two possibilities:

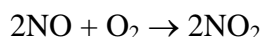

R-I

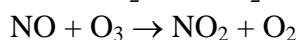

R-II

the second is about four orders of magnitude faster. Therefore, the formation of nitrogen dioxide from the emitted NO depends on the availability of ozone.

Photolytic reactions

A very important characteristic of smog is that it requires sunlight, which causes the *photolysis* of various chemicals into smaller fragments (*photo* = light; *lysis* = breaking). Examples of sequences of reactions triggered or followed by photolysis:



and



The rate of photolytic reactions is usually given by an expression equivalent to Eq. (2.10), with the pre-exponential factor taken as a function of incident solar radiation. Hence the photolytic reaction rates are functions of the cloud cover and latitude in a given location, in addition to the time of the day and season. Smog is more common in sunny cities and in the summer because R-III (and other photolytic reactions) proceeds faster.

The photostationary state

Reactions R-II, R-III and R-IV suggest the following “cycle” for ozone: R-III produces an oxygen atom, which results in ozone formation through R-IV, which then reacts with NO in R-II. It is a common assumption that these reactions proceed very fast compared to others in smog chemistry and then the oxygen atom and ozone reach a quasi-steady state, called the “*photostationary state*”. If we assume that $d[\text{O}]/dt=0$ and $d[\text{O}_3]/dt=0$ and we use the Law of Mass Action for the three reactions (R-II to R-IV), we get that

$$[\text{O}_3] = \frac{k_{III}[\text{NO}_2]}{k_{II}[\text{NO}]} \quad (2.11)$$

where k_{II} and k_{III} are the reaction rate constants for R-II and R-III respectively. Therefore we expect ozone (and smog) to be in high concentrations around midday when the photolytic reaction R-III has its peak. We also expect ozone to decrease to low values at night. Both these observations are approximately borne out by measurements. Above heavily polluted cities in the mornings, Eq. (2.11) is not very accurate due to the presence of VOC's, which also produce NO_2 , as we shall see below. In the afternoons, when VOC's tend to decrease due to their own photolysis, Eq. (2.11) is not a bad approximation.

The hydrocarbons

A prerequisite for smog is the presence of hydrocarbons, collectively called VOC's. A global reaction describing their participation in smog formation is



where VOC^* denotes some other organic radical. The NO_2 will then follow the cycle in R-II, R-III and R-IV, which releases ozone. During the VOC chemistry, the major eye irritant $\text{CH}_3\text{COO}_2\text{NO}_2$ may also appear (called peroxyacetyl nitrate or PAN). We see therefore that a combination of

nitrogen oxide emission and hydrocarbons will under the action of sunlight cause serious pollution. The situation is worse above cities than above rural areas due to the high emissions from cars and other activities. The chemistry of smog formation is extremely more complex than the above over-simplified picture and is the subject of intensive research.

Acid rain

Sulphur from oils and coal is usually oxidised during combustion and is then emitted in the form of SO_2 , which will react in the atmosphere according to:



i.e. sulphuric acid is formed. This is absorbed on water droplets and may be deposited on the ground by rain. This is the notorious “*acid rain*”, a term that also includes nitric acid that is similarly formed. The situation has improved the last decade with the use of scrubbers in power stations, which capture SO_2 before it is emitted.

2.4 Some comments on the atmosphere

It is important to realize that the atmosphere at various heights behaves very differently, not only in terms of the chemistry that takes place, but also in terms of the fluid mechanics we see. Most pollution problems occur at the lower levels, although the ozone hole and global warming are issues of the higher levels too. Here, we present briefly the structure of the lower atmosphere, which will be necessary for understanding the atmospheric dispersion processes in Chapter 4.

Atmospheric structure

Pressure, temperature, “standard atmosphere”

The pressure, density, and temperature of the atmosphere are related with height through

$$\frac{dp}{dz} = -\rho g \quad (2.12)$$

$$p = \rho RT \quad (2.13)$$

$$\frac{dT}{dz} = -\frac{g}{c_p} \quad (2.14)$$

where $R=R^0/MW_{air}$. Equation (2.14) gives the Dry Adiabatic Lapse Rate (DALR) as 9.3 K/km. We very often use the “*standard atmosphere*” lapse rate, an average over all seasons of the year and across many regions of the globe, which is about 6.5 K/km. This can then be used in Eqs. (2.12) and (2.13) to find the vertical pressure and density distribution.

The boundary layer and the troposphere, inversions

The troposphere is the first 11 km above sea level and contains 75% of the mass of the whole atmosphere. It is usually divided into the *boundary layer* and the *free troposphere*. The boundary layer depth ranges between 500 and 3000 m and it is divided into the *surface layer* (the

first 10% closest to the ground) and the *neutral convective layer*, also called the *mixed layer*. At the top of the boundary layer, we have the *inversion layer*. This structure is shown on Fig. 2.1.

It is important to realize that because the ground changes temperature quicker than the air, it affects the air immediately above it and hence the temperature locally in the surface layer may have a different gradient than the DALR. Therefore, the vertical temperature gradient will be different during the day and at night, which affects the stability of the layer. At night, the surface layer and a large part of the mixed layer become stable as the temperature increases with height due to radiative cooling of the ground.

At the top of the boundary layer, the temperature gradient is usually positive (i.e. stable) and the turbulence dies there. This is the inversion layer. Between the inversion and the neutral layers, we have the so-called entrainment zone, which is where we see often cloud formation. Because it is not easy to penetrate the inversion layer, it can be considered as the *ceiling of pollution*. Therefore, most of the pollution emitted at ground level will disperse approximately up to the first 3 km of the atmosphere, with further diffusion to the free troposphere being a slower process.

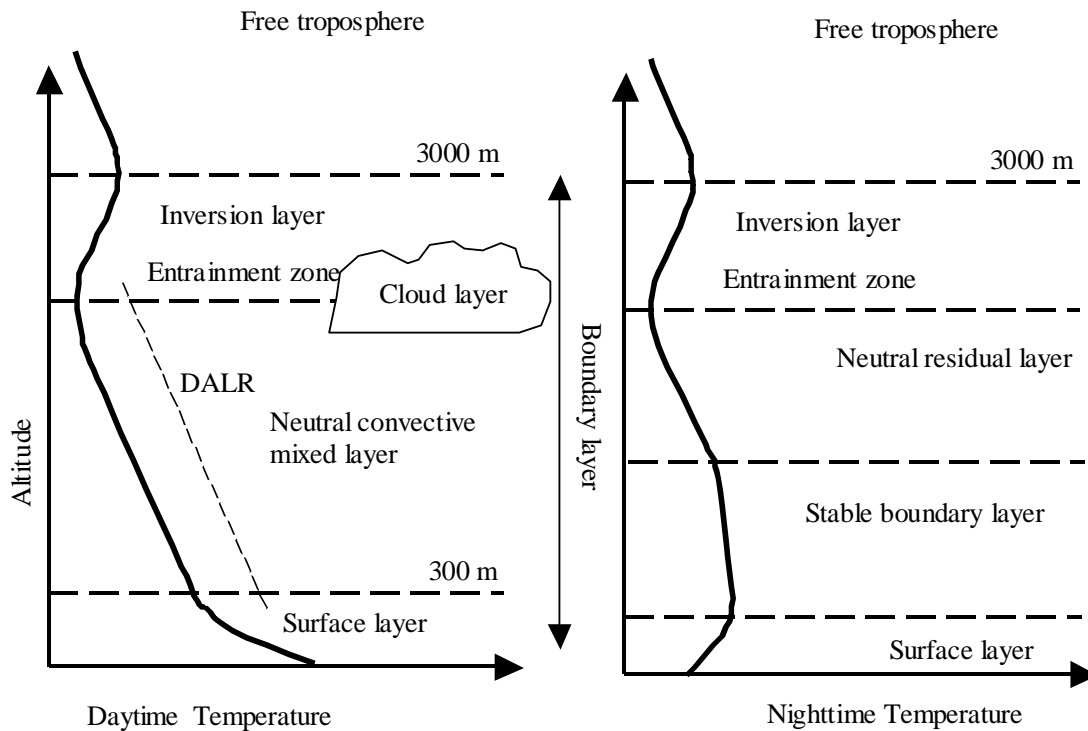

Figure 2.1 Variation of temperature in the atmospheric boundary layer with height during day and night (from Jacobson, 1998).

Mixing height

Figure 2.1 also serves to visualize another very important quantity in the field of atmospheric pollution dispersion: that of the *mixing height*. With this we simply mean the height above ground where the inversion occurs, which means that the turbulence dies and hence stops mixing. So, for Fig. 2.1 during day, the mixing height would be at 3000 m.

For dawn and early morning, the situation is better visualized in Fig. 2.2, where we look at various times progressively after sunrise. Curve A shows a stable stratification at dawn. The air is

still due to the damping effect of the stable atmosphere during the night and hence no mixing can occur. As the ground heats up due to the sun radiation, the temperature profile becomes like that of Curve B and the mixing height is small, say 100 m. Therefore, the first 100 m will have turbulence and mixing can occur. As time goes on, the mixing height increases because the unstable layer close to the ground becomes thicker. At mid or late afternoon, the mixing height has reached the inversion layer of the atmospheric boundary layer shown in Fig. 2.1.

The fact that the mixing height changes during the day and that often no significant mixing may be expected at night, has tremendous implications for local pollution episodes, as we will discuss more fully in Chapter 4.

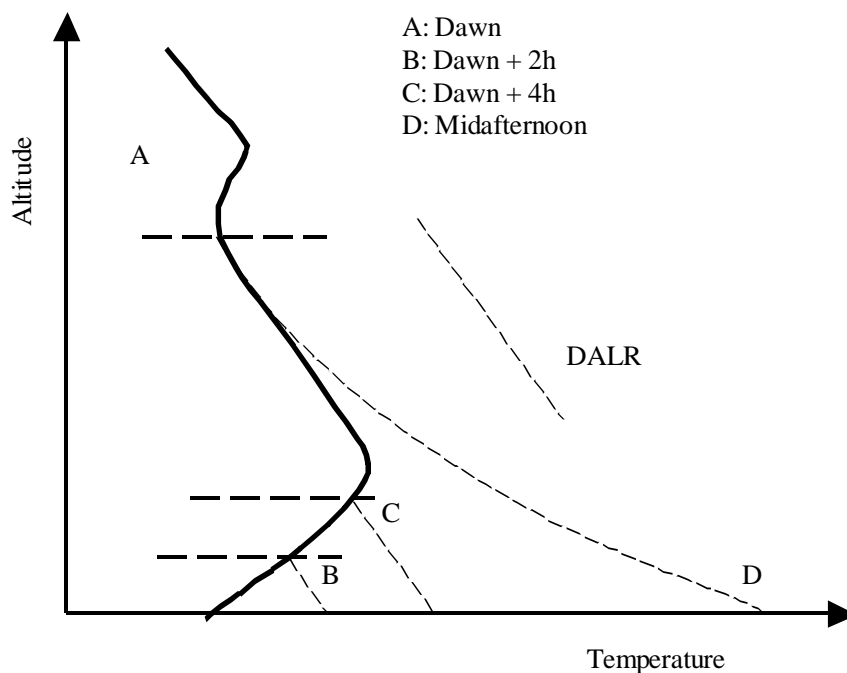

Figure 2.2 Variation of the temperature at various times during a typical morning. The mixing height increases with time. (Adapted from De Nevers, 1995.)

2.5 Global warming

“Global warming” is a much-used (and abused) phrase. It refers to the increase in the average temperature of the atmosphere caused by an enhanced greenhouse effect, which in turn is caused by increased concentrations of some gases in the atmosphere. “Climate change” is a more general term that refers to changes in the climate (which can include cooling) due to the anthropogenic emissions. Cooling in one point of the planet may be caused by warming in another point, so a discussion of the greenhouse effect, and how this is affected by emissions, is necessary for understanding all these phenomena. For a nice summary, see:

http://en.wikipedia.org/wiki/Global_warming

The key scientific topic is the radiative balance in the atmosphere, which is discussed next. Consider Fig. 2.3, which shows a planet in the path of radiation. Assume an incoming solar flux of

S (W/m^2) incident on the outer layers of the atmosphere. This solar radiation is intercepted by the planet's projected area (πR^2), where R is the planet's radius,

Assume that the surface is uniform (i.e. same radiative properties and temperature everywhere) and let us neglect at this stage the presence of the atmosphere. Thermodynamic equilibrium implies that the net heat falling on the surface balances the heat emitted by the surface:

$$\pi R^2(1-\alpha)S = 4\pi R^2\varepsilon\sigma T_s^4 \quad (2.15)$$

giving

$$T_s = [(1-\alpha)S / 4\varepsilon\sigma]^{1/4} \quad (2.16)$$

where T_s is the surface temperature, ε the emissivity of the surface, α the albedo (the fraction of incident radiation that is reflected), σ the Stefan-Boltzmann constant (equal to $5.67 \times 10^{-8} \text{ W}/\text{m}^2/\text{K}^4$). For Earth, the emissivity and the albedo are not constant (they depend on the nature of the surface, whether it is covered by water, ice, vegetation etc), but some average values are 0.61 and 0.3 respectively. These effective values *include* the presence of the atmosphere, clouds etc. Given that $S \approx 1367 \text{ W}/\text{m}^2$, we get that $T_s = 288 \text{ K}$. This is an estimate of the Earth's average surface temperature, in the sense of an effective radiative temperature. Eq. (2.16) also shows the great sensitivity of the surface temperature in changes of solar radiation, albedo and emissivity; 1 K change can be brought about by 1-2% change in these parameters. Note that the greenhouse effect (discussed below) is already included in the effective values of emissivity and albedo.

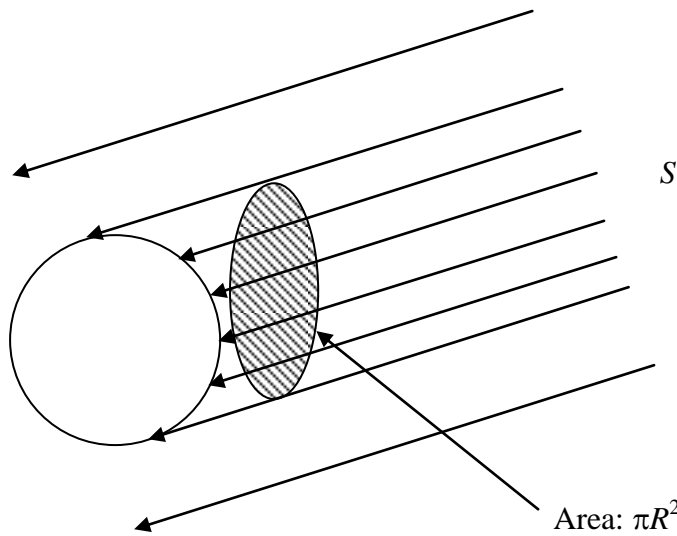
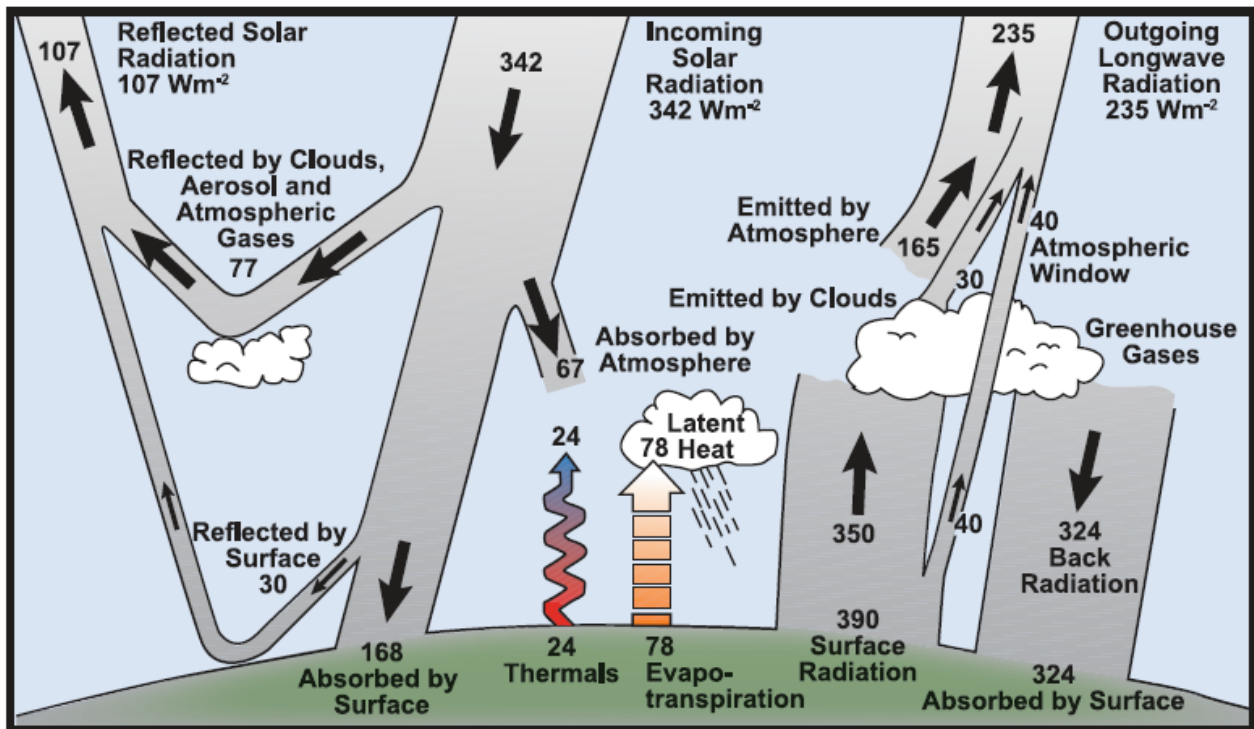

Figure 2.3 Simplified view of Earth's receiving radiation from the sun.

In a more detailed view, Fig. 2.4 shows the various heat exchange processes taking place between the Earth's surface and the incoming solar radiation (note that in this picture the solar radiation is expressed in terms of m^2 of the total Earth's surface area). The greenhouse gases (mainly water vapour, methane, and CO_2) absorb some of the radiated heat from the surface and re-radiate it back

to the surface, which results in a warming of the surface. If there were no greenhouse gases at all, the surface would be very cold for human life, while if their concentration increases, the re-radiated fraction increases.

The presence of atmospheric aerosols (natural or man-made) increases the reflection of the sun's radiation, and therefore their presence can act so as to reduce the surface temperature. The power generation and the transport sectors produce significant amounts of aerosols and their effect on climate change is a very important topic of current research. More on aerosols in a later part of this course.



FAQ 1.1, Figure 1. Estimate of the Earth's annual and global mean energy balance. Over the long term, the amount of incoming solar radiation absorbed by the Earth and atmosphere is balanced by the Earth and atmosphere releasing the same amount of outgoing longwave radiation. About half of the incoming solar radiation is absorbed by the Earth's surface. This energy is transferred to the atmosphere by warming the air in contact with the surface (thermals), by evapotranspiration and by longwave radiation that is absorbed by clouds and greenhouse gases. The atmosphere in turn radiates longwave energy back to Earth as well as out to space. Source: Kiehl and Trenberth (1997).

Figure 2.4 Energy exchanges in the atmosphere (From the IPCC 4th Assessment Report; "Climate Change 2007: The Physical Basis", CUP, 2007)

2.6 Overview

Figure 2.5 gives in summary form the key pollutants encountered in the atmosphere, both at urban scale and at global scale.

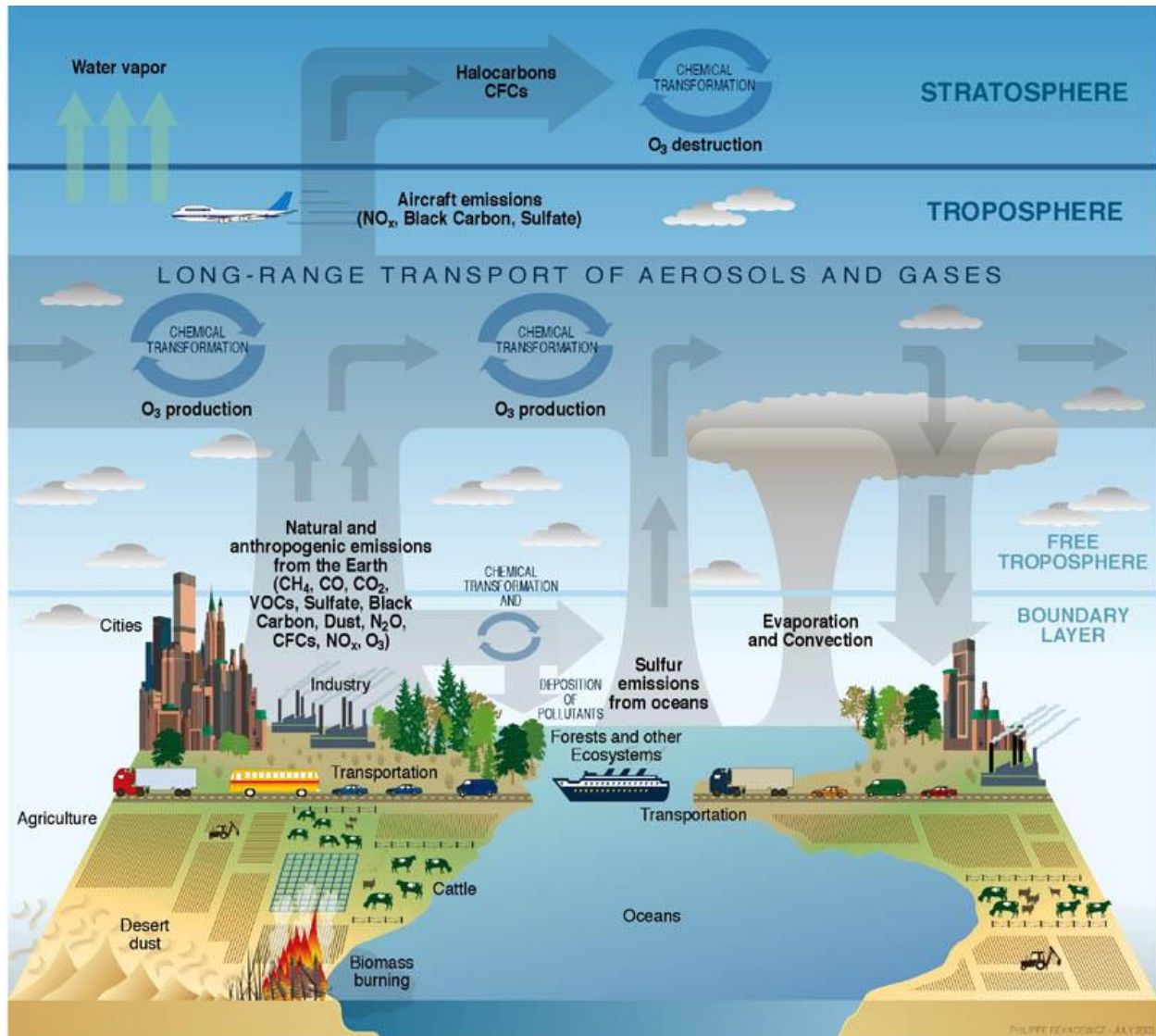

Figure 2.5 Paths of the various atmospheric pollutants (source: unknown. Note from author: apologies, this is too nice a diagram not to show because I cannot find its source!).

2.7 Worked Examples

Example 2.1

An air quality monitoring station measured one early morning that the volume fractions of NO, ozone and NO₂ were 30, 40, and 170 ppb respectively. What were the corresponding concentrations in kmol/m³, in molecules/m³, and in kg/m³? The atmospheric conditions at the time of the measurement were 980 mbar pressure and 10°C temperature.

Solution

From Eq. (2.6), $C_i = X_i P / R^0 T$, and using $P=0.98 \times 10^5$ Pa, $T=283$ K, $R^0=8315$ J/kmol/K, we get that $C_{NO} = 30 \times 10^{-9} \times 98 \times 10^3 / (8315 \times 283) = 1.24 \times 10^{-9}$ kmol/m³. Note that the 30 ppb becomes a volume fraction of 30×10^{-9} . Similarly for the other species. To transform the kmol/m³ into molecules/m³, we need to multiply by Avogadro's Number, 6.022×10^{26} molecules/kmol. To get the concentration in kg/m³, we multiply the molar concentration by the molecular weight of the species.

Example 2.2

Estimate the mass of the air in the atmospheric boundary layer, assuming a total height of 3 km and a linear reduction of temperature with height of 6.5 K/km (the "standard atmosphere") from a mean ground-level temperature of 288 K.

Solution

The standard atmosphere gives that $T(z) = T(0) - 6.5z$, where z is measured in km and $T(0)=288$ K. The total mass of the air $M(z)$ in the atmosphere up to a height z per unit area is given by $M(z) = \int_0^z \rho dz$. Writing $dT/dz = -a$ and using the hydrostatic balance equation $dP/dz = -\rho g$, differentiation of the equation of state $p = \rho RT$ gives:

$$dp/dz = d\rho/dz RT + \rho R dT/dz \Leftrightarrow RT d\rho/dz = -\rho g + \rho R a \Leftrightarrow \frac{d\rho}{\rho} = \frac{aR - g}{R} \frac{dz}{T(0) - az}$$

$\Leftrightarrow \ln \left[\frac{\rho(z)}{\rho(0)} \right] = \frac{g - aR}{aR} \ln \left[\frac{T(0) - az}{T(0)} \right] \Leftrightarrow \rho(z) = \rho(0) \left[\frac{T(0) - az}{T(0)} \right]^{\frac{g}{aR} - 1}$. So at $z=3$ km, the density of air is 0.9 kg/m³ and the temperature 268.5 K (-4.5 °C). The density variation can now be integrated to give:

$$M(z) = \int_0^z \rho dz = \frac{1}{m+1} \frac{\rho(0)}{aT(0)^m} \left[T(0)^{m+1} - T(z)^{m+1} \right], \quad m = \frac{g}{aR} - 1.$$

With $a=6.5$ K/km and $z=3$ km, the total mass per unit area becomes 3143.7 kg/m². Note that if we had used the average value between $[\rho(0)+\rho(3\text{km})]/2$ we would have obtained a mass per unit area of 3160.5 kg/m². The fact that this estimate is so good reflects the fact that inside the boundary layer the density changes almost linearly with height (but not outside it).

To find the total mass, we must multiply by the surface area of the Earth, which is $4\pi R_{\text{earth}}^2$, and this gives a total mass in the boundary layer of 1.6×10^{18} kg. This corresponds to about 30% of the mass of the whole atmosphere.

Example 2.3

Assume that the average car emits 0.2 kg CO₂ per km driven. The average user drives 10,000 km per year and there are about 450,000,000 cars in the world today. Estimate the yearly increase of CO₂ in the atmosphere in ppb due to car emissions.

Solution

The total CO₂ released per year from all cars is $0.2 \times 10,000 \times 450,000,000 = 9 \times 10^{11}$ kg per year. From Example 2.2, the total atmospheric mass will be $1.6 \times 10^{18} / 0.3 = 5.3 \times 10^{18}$ kg. Then the volume fraction of CO₂ will be from Eq. (2.3): $X_{\text{CO}_2} = Y_{\text{CO}_2} \times (29/44) = (9 \times 10^{11} / 5.3 \times 10^{18}) \times (29/44)$, i.e. 112 ppb increase per year.

The *measured* increase in CO₂ concentration in the atmosphere is about 1100 ppb per year (Jacobson, 1998). This includes power generation, industry and land use. Figures including the whole of the transport sector (e.g. buses, trucks, trains etc.) and with more exact values for the average mileage and CO₂ emitted per vehicle give that the contribution of transport is about 24% of the CO₂ releases, which is estimated to be a total of 6.2×10^{12} kg/year.

3. Statistical description of turbulent mixing

In this Chapter, we will derive the governing equation for a reacting scalar in a turbulent flow and we will demonstrate why the turbulence affects the mean reaction rate. We will also present concepts from probability theory that are useful for understanding why the concentration fluctuations are important in environmental pollution and for providing measures to describe these. The material here is needed background for understanding the practical Air Quality Modelling techniques introduced in later Chapters.

3.1 Governing equation for a reacting scalar

Conservation of mass

Consider an infinitesimal control volume ΔV (Fig. 3.1). Inside the CV we have a uniform mixture of species undergoing chemical reactions. Mass may cross the surfaces of the CV. For simplicity of presentation we assume a one-dimensional geometry. Then, the principle of mass conservation of each species i reads:

$$[\text{Rate of accumulation}] = [\text{Rate at which species comes in}] - [\text{Rate at which species leaves}] + [\text{Rate of generation due to reaction}]$$

In mathematical terms,

$$\frac{\partial(m_V Y_i)}{\partial t} = m_i'' \Delta y \Delta z - (m_i'' + \Delta m_i'') \Delta y \Delta z + \dot{w}_i \Delta V \quad (3.1)$$

with the following definitions:

m_V	(kg)	total mass of mixture inside the control volume, $m_V = \rho \Delta x \Delta y \Delta z$
Y_i	(-)	mass fraction of i
ρ	(kg m ⁻³)	mixture density
m_i''	(kg m ⁻² s ⁻¹)	mass flow of species i per unit time per unit surface, the <i>mass flux</i>
\dot{w}_i	(kg m ⁻³ s ⁻¹)	mass of species generated per unit volume per unit time due to chemical reactions

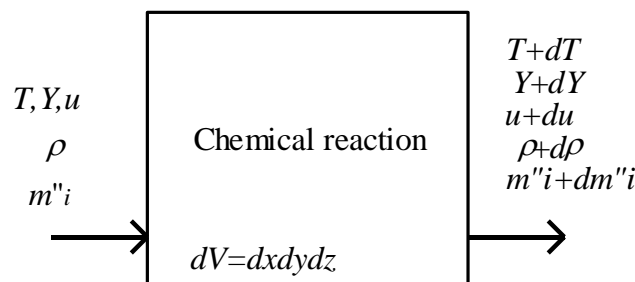

Figure 3.1 Control volume for derivation of species conservation equation.

Letting Δx go to zero, we obtain the *species conservation equation*:

$$\frac{\partial(\rho Y_i)}{\partial t} = -\frac{\partial m_i''}{\partial x} + \dot{w}_i \quad (3.2)$$

Equation (3.2) is a partial differential equation (in time and space) and to be in a position to solve it, we need expressions for the mass flux and the rate of generation due to chemistry. The latter was covered in Section 2.1, while the former is discussed next.

Mass flux, mass transfer and Fick's Law of diffusion

The mass flux m_i'' for each species that appears in the species conservation equation is composed of two parts: an *advective* and a *diffusive* part. This result is given here without proof, as it can be proven from the Kinetic Theory of Gases (4A9, Part IIB).

$$m_i'' = m_{i,ADV}'' + m_{i,DIFF}'' \quad (3.3)$$

The advective mass flux is due to the bulk fluid motion and is given by:

$$m_{i,ADV}'' = Y_i m'' = Y_i \rho u \quad (3.4)$$

For the purposes of this course, the diffusive mass flux is given by *Fick's Law*:

$$m_{i,DIFF}'' = -\rho D \frac{\partial Y_i}{\partial x} \quad (3.5)$$

Fick's Law states that the mass flux is proportional to the gradient of the mass fraction of the species. This is a diffusion process because it tends to make concentration gradients more uniform, i.e. it mixes the various species together. The coefficient D (m^2/s) is the *diffusion coefficient* and, in general, depends on the nature of the diffusing species. For gases, it is a common approximation that the diffusion of heat and mass follow the same rate, i.e. D is related to the conductivity λ :

$$\rho D = \frac{\lambda}{c_p} \quad (3.6)$$

Equation (3.6) serves us to estimate D because tabulated values of conductivity and heat capacity are usually available. Throughout this course we assume that the diffusivity will be given by Eq. (3.6) with ρ , λ , and c_p taken as those of air at atmospheric conditions.

Final instantaneous species conservation equation

With these expressions, the species conservation equation takes the final form:

$$\frac{\partial(\rho Y_i)}{\partial t} + \frac{\partial(\rho u Y_i)}{\partial x} = \frac{\partial}{\partial x} \left(\rho D \frac{\partial Y_i}{\partial x} \right) + \dot{w}_i \quad (3.7)$$

It is important to know the physical mechanisms contributing to this equation: the first term in the l.h.s. corresponds to accumulation of species i , the second to advection by the bulk fluid motion, the first term in the r.h.s. corresponds to molecular diffusion and the last to the generation by the chemical reactions.

In more dimensions and for a generic scalar ϕ that is proportional to the mass fraction (e.g. our usual concentration in atmospheric pollution expressed in kg/m^3), the governing transport conservation equation becomes:

$$\frac{\partial \phi}{\partial t} + u_j \frac{\partial \phi}{\partial x_j} = D \frac{\partial^2 \phi}{\partial x_j^2} + \dot{w} \quad (3.8)$$

in Cartesian tensor notation, where we have assumed an incompressible flow and a constant diffusivity, typically excellent assumptions in environmental fluid mechanics. If the scalar is inert, then simply $\dot{w} = 0$. Equation (3.8) is our starting point for examining turbulent mixing in the following Sections.

3.2 The averaged equations for a reactive scalar

Averaged species conservation equation

In a turbulent flow, we can write that the instantaneous mass fraction of a scalar is $\phi = \bar{\phi} + \phi'$ and that the velocity is $u = \bar{u} + u'$. It is easy to see that, by performing Reynolds decomposition and performing the averaging procedure (“The average of an average is the average”; “The average of a fluctuation is zero”; “The average of a product of fluctuations is not zero”) on Eq. (3.8), we get:

$$\frac{\partial \bar{\phi}}{\partial t} + \frac{\partial (\bar{u}_j \bar{\phi})}{\partial x_j} + \frac{\partial (\overline{u'_j \phi'})}{\partial x_j} = D \frac{\partial^2 \bar{\phi}}{\partial x_j^2} + \bar{\dot{w}} \quad (3.9)$$

The first term in the l.h.s. is the unsteady accumulation of ϕ , the second is due to mean advection, and the third is due to turbulent transport (or turbulent diffusion). The first term in the r.h.s. is due to molecular diffusion and the second is the mean reaction rate.

Modelling the scalar flux – the eddy diffusivity

It is usual engineering practice to model the turbulent transport term using the *eddy diffusivity* concept, also known as the *gradient approximation*. This model is motivated from the Kinetic Theory of Gases, where the mass flux is found to be proportional to the gradient of the mass fraction (Eq. 3.5) and the molecular diffusivity D is found to be proportional to the mean molecular speed and the mean free path between molecular collisions. By making an analogy between the random turbulent motions of “fluid particles” and the random molecular motion in a fluid, the turbulent transport term is written as

$$\overline{u'_j \phi'} = -D_T \frac{\partial \bar{\phi}}{\partial x_j} \quad (3.10)$$

with the eddy diffusivity D_T given by

$$D_T = C u' L_{turb} \quad (3.11)$$

By a trial-and-error procedure and comparison with experimental data, the constant C is found to be around 0.1, but this depends on how L_{turb} is defined. There is a lot of criticism behind the use of the gradient approximation for modelling turbulent transport and indeed sometimes Eqs. (3.10) and/or (3.11) fail to predict the correct magnitude of $\overline{u'_j \phi'}$. Nevertheless, the eddy diffusivity concept remains a very useful approximation for providing a tractable closure to Eq. (3.9), which then becomes:

$$\frac{\partial \bar{\phi}}{\partial t} + \bar{u}_j \frac{\partial \bar{\phi}}{\partial x_j} = \frac{\partial}{\partial x_j} \left[(D + D_T) \frac{\partial \bar{\phi}}{\partial x_j} \right] + \bar{w} \quad (3.12)$$

Note that D_T may be a function of space and hence should be kept inside the derivative in the r.h.s. of Eq. (3.12). The eddy diffusivity concept is usually much better for an *inert* scalar than for a reacting scalar, but we use it anyway.

For high Reynolds numbers $D \ll D_T$, which suggests that the molecular diffusion may be neglected. To illustrate this, consider a wind flow of 5 m/s with a typical turbulence intensity of 10%, so that $u' = 0.5$ m/s. In the atmospheric boundary layer, the lengthscale is proportional to the height above the ground. Let us take that $L_{turb} = 500$ m. Then $D_T = 25$ m²/s. At standard temperature and pressure, the molecular diffusivity of air is 2.2×10^{-5} m²/s (convince yourselves with Eq. 3.6). Therefore the diffusion caused by molecular motions is negligible compared to the diffusion due to turbulence, which is a typical feature of turbulent flows at large Reynolds numbers. Molecular action is *always* present at the smallest (e.g. Kolmogorov) scales, but these contribute very little to the overall diffusion of the scalar (the small eddies just don't "move far enough"). In other words, "where the smoke goes" is a function of the large scales only and the turbulent diffusivity suffices.

Governing equation for the fluctuations

Starting from the instantaneous equation and performing the Reynolds decomposition, a series of transport equations for the higher moments may also be derived. Using $\phi = \bar{\phi} + \phi'$ and $u = \bar{u} + u'$ in the instantaneous scalar equation (3.8) we get (before averaging):

$$\frac{\partial(\bar{\phi} + \phi')}{\partial t} + (\bar{u}_j + u'_j) \frac{\partial(\bar{\phi} + \phi')}{\partial x_j} = D \frac{\partial^2(\bar{\phi} + \phi')}{\partial x_j^2} + \bar{w} + w' \quad (3.13)$$

Multiplying by ϕ' , expanding the derivatives and collecting terms gives:

$$\begin{aligned} \phi' \left[\frac{\partial \bar{\phi}}{\partial t} + \bar{u}_j \frac{\partial \bar{\phi}}{\partial x_j} - D \frac{\partial^2 \bar{\phi}}{\partial x_j^2} - \bar{w} \right] + \phi' \frac{\partial \phi'}{\partial t} + \bar{u}_j \phi' \frac{\partial \phi'}{\partial x_j} + \phi' u'_j \frac{\partial \bar{\phi}}{\partial x_j} + \phi' u'_j \frac{\partial \phi'}{\partial x_j} = \\ = D \phi' \frac{\partial^2 \phi'}{\partial x_j^2} + \phi' w' \end{aligned} \quad (3.14)$$

We now perform the averaging procedure on Eq. (3.14). The term in the square brackets disappears because it is already averaged and is multiplied by ϕ' ($\overline{\phi'} = 0$). Writing $\overline{\phi'^2} = \sigma^2$, using the fact that

$$\phi' \frac{\partial \phi'}{\partial t} = \frac{\partial (1/2 \phi'^2)}{\partial t} \Leftrightarrow \overline{\phi' \frac{\partial \phi'}{\partial t}} = \frac{\partial (1/2 \sigma^2)}{\partial t},$$

and similarly for the spatial derivatives, and using

$$\phi' \frac{\partial^2 \phi'}{\partial x_j^2} = \frac{\partial}{\partial x_j} \left(\phi' \frac{\partial \phi'}{\partial x_j} \right) - \left(\frac{\partial \phi'}{\partial x_j} \right)^2 \Leftrightarrow \overline{\phi' \frac{\partial^2 \phi'}{\partial x_j^2}} = \frac{\partial^2 (1/2 \sigma^2)}{\partial x_j^2} - \overline{\left(\frac{\partial \phi'}{\partial x_j} \right)^2}$$

Eq. (3.14) becomes:

$$\frac{\partial \sigma^2}{\partial t} + \bar{u}_j \frac{\partial \sigma^2}{\partial x_j} + 2 \overline{\phi' u'_j} \frac{\partial \bar{\phi}}{\partial x_j} + \overline{2 \phi' u'_j \frac{\partial \phi'}{\partial x_j}} = D \frac{\partial^2 \sigma^2}{\partial x_j^2} - 2D \overline{\left(\frac{\partial \phi'}{\partial x_j} \right)^2} + 2 \overline{\phi' \dot{w}'} \quad (3.15)$$

This is the governing equation for the variance of the fluctuations of a reactive scalar. It contains more correlations than the first-moment equation (Eq. 3.9) and the correlation between the chemistry and the fluctuating scalar. This quantity is particularly difficult to model accurately, and so Eq. (3.15) has not found yet much direct use. However, for an *inert* scalar, there is a lot of theoretical and experimental work that guides the modelling of the unclosed terms in this equation. In particular, using the gradient approximation for the turbulent transport term (Eq. 3.10) and a similar gradient approximation for the third-order correlation (the fourth term in the l.h.s. of Eq. 3.15), the modelled transport equation for the variance of the fluctuations of an *inert* scalar is:

$$\frac{\partial \sigma^2}{\partial t} + \bar{u}_j \frac{\partial \sigma^2}{\partial x_j} = D \frac{\partial^2 \sigma^2}{\partial x_j^2} + \frac{\partial}{\partial x_j} \left(D_T \frac{\partial \sigma^2}{\partial x_j} \right) + 2D_T \overline{\left(\frac{\partial \bar{\phi}}{\partial x_j} \right)^2} - 2D \overline{\left(\frac{\partial \phi'}{\partial x_j} \right)^2} \quad (3.16)$$

The first term in the l.h.s. is the unsteady accumulation of fluctuations and the second the advection by the mean flow. The first term in the r.h.s. is the molecular diffusion of the fluctuations (essentially zero for high Re flows) and the second term is the turbulent diffusion of the fluctuations. The third term is always positive and is hence called a *production* term (analogous to production of turbulent kinetic energy by the mean shear), while the last term always acts like a sink and hence is called the *scalar dissipation*, denoted usually as χ or ε_ϕ . The usual model for the scalar dissipation is motivated by the insight that the rate at which the fluctuating “energy” moves down the eddy cascade to be dissipated by molecular action is determined by the large-scale features only. This gives

$$\varepsilon_\phi = 2D \overline{\left(\frac{\partial \phi'}{\partial x_j} \right)^2} = 2 \frac{u'}{L_{turb}} \sigma^2 = \frac{2}{T_{turb}} \sigma^2 \quad (3.17)$$

Note the eventual disappearance of the molecular diffusivity from Eqs. (3.16) and (3.12) for high Reynolds numbers. Equation (3.17) is a very useful model and we need it if we want to examine the decay of the fluctuations.

Practical application

We will use solutions of Eq. (3.12) for the *plume dispersion* problem in uniform wind in Chapter 4. In Air Quality Modelling, Eq. (3.12) is solved by complicated computer codes that take the velocity field \bar{u}_j from a weather prediction program. Then, some assumptions are used for the chemistry and the solution to Eq. (3.12) gives “where the pollutant goes”, given an initial release. Such codes, for example, are used to simulate how the pollution above a city is dispersed or how pollution from one country reaches another.

Equation (3.12) is not only valid for pollution, but also for any other inert or reacting scalar. It is also valid for temperature. The need to predict *heat transfer* in engineering has motivated the development of Computational Fluid Dynamics codes that solve not only Eq. (3.12), but also the mean velocity field using some turbulence model. CFD is a very large commercial and research activity today and there are many off-the-shelf codes, aimed at engineering and environmental flows alike, although most of the development has been done for the former. Some of these codes also include the equation for the fluctuations (3.16) because this quantity is an ingredient to some turbulent reacting flows models. To know σ is important in its own right for environmental pollution problems, as the *range* of possible pollutant concentrations may be equally important (or even equally legislated) as the mean value. We will be returning to this issue often.

The source term problem

We now discuss how the reaction is affected by the turbulence. Assume that there are only two reactants, A and B, that react according to the elementary reaction $A + B \rightarrow C$ to give species C. Take the scalar ϕ to be the concentration of A, B, or C. Then, the rate of production or destruction of these species that appears in Eq. (3.8) or (3.9) can be written as

$$\dot{w}_A = -k [A][B], \quad \dot{w}_B = -k [A][B], \quad \dot{w}_C = k [A][B] \quad (3.18)$$

Writing $[A] = \bar{[A]} + [A]'$, $[B] = \bar{[B]} + [B]'$, $[C] = \bar{[C]} + [C]'$, we obtain that

$$\begin{aligned} \dot{w}_A &= -k [A][B] = -k (\bar{[A]} + [A]')(\bar{[B]} + [B]') \Leftrightarrow \\ \overline{\dot{w}_A} &= -k (\bar{[A]} \bar{[B]} + \overline{[A]'[B]'}) \end{aligned} \quad (3.19)$$

Equation (3.19) is extremely important. It shows that the mean reaction rate is not equal to the product of the mean concentrations. A straightforward application of the Law of Mass Action with the mean concentrations replacing the instantaneous values is wrong. The appearance of the correlation $\overline{[A]'[B]'}$ is the effect of turbulence on the mean reaction rate. It is not clear if this term is positive, negative, small or large. Its value and contribution to Eq. (3.19) depends on the problem. Providing models for this correlation is the objective of turbulent reacting flow theories and the subject of intensive research of engineers, mathematicians and physicists for more than 30 years. In Chapter 5, we will present a method that helps to partly solve this problem, but we need some additional background, which is given next.

3.3 The probability density function and averages

Concept of pdf

Figure 3.2 shows two possible time traces in a turbulent flow, e.g. of velocity u or of an inert or reactive scalar ϕ . If we measure how long the signal takes values between v and $v+\Delta v$, and then plot this quantity as a function of v , we get the curves on the right of the time trace. This is the *probability density function* of u . (v is called the random space variable of u ; it is used, rather than u , for notational clarity.) In other words:

- the probability of finding u in the region between v and $v+\Delta v$ is $P(v)\Delta v$.

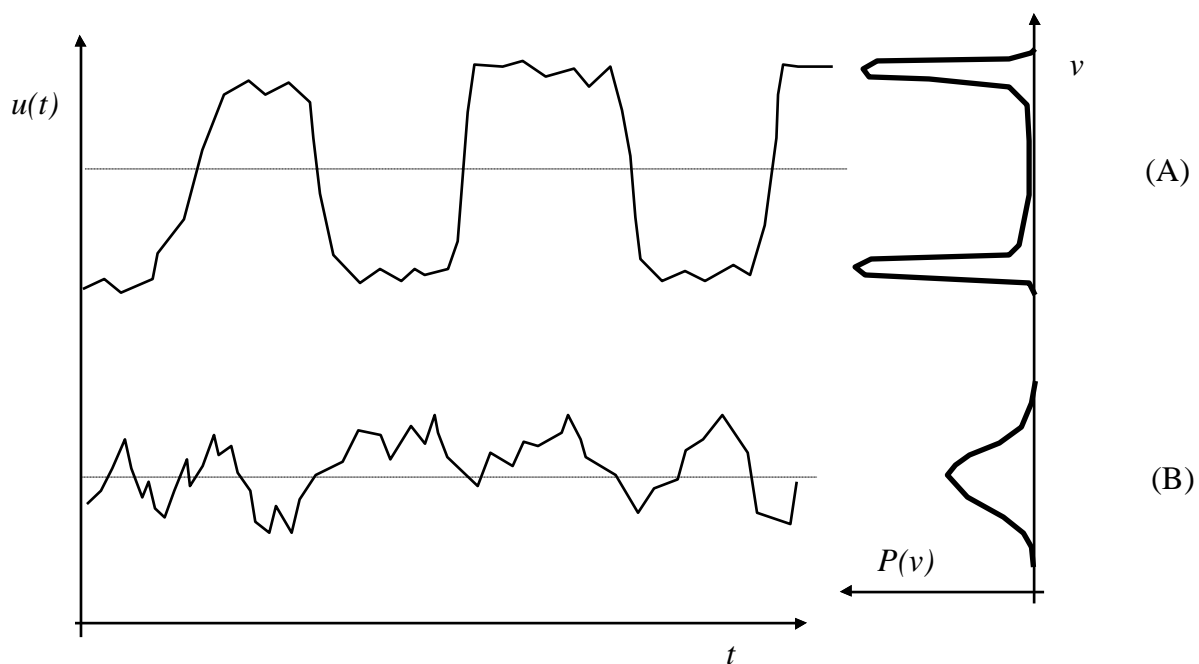

Figure 3.2 Typical time series of signals with bimodal (A) or unimodal (B) pdfs. The dashed line shows the mean value.

Comments on the pdf

Cumulative distribution function:

The probability of finding $u < v$ is called the cumulative distribution function $F(v)$. If the sample space of v is between a and b (i.e. the physics of the problem dictate that always $a < u < b$), then

$$F(v) = \int_a^v P(t') dt' \quad (3.20a)$$

$$F(a) = 0 \quad (3.20b)$$

$$F(b) = 1 \quad (3.20c)$$

The probability of finding u between v_1 and v_2 is

$$F(v_2) - F(v_1) = \int_{v_1}^{v_2} P(t') dt' \quad (3.20d)$$

which implies that

$$P(v) = \frac{dF(v)}{dv} \quad (3.20e)$$

Normalization condition:

$$\int_a^b P(v) dv = 1 \quad (3.21)$$

Mean and variance

For any function $y = f(u)$, if u is distributed according to $P(u)$ (for simplicity, we now drop the difference between the sample space variable v and the real random variable u), we have that the average of y is given by:

$$\bar{y} = \overline{f(u)} = \int_a^b f(u) P(u) du \quad (3.22)$$

The average value of u itself is

$$\bar{u} = \int_a^b u P(u) du \quad (3.23)$$

In turbulence, it is convenient to work in terms of the fluctuation $u' = u - \bar{u}$. Then, the mean of the fluctuation is

$$\overline{u'} = \overline{u - \bar{u}} = \int_a^b (u - \bar{u}) P(u) du = \int_a^b u P(u) du - \int_a^b \bar{u} P(u) du = \bar{u} - \bar{u} = 0 \quad (3.24)$$

So the mean of the fluctuation does not tell us anything useful. We would particularly like to know how large is the excursion around the mean (i.e. how “far” the signal in Fig. 3.2 travels away from the mean). For this we use the *variance*, which is defined as

$$\sigma^2 = \overline{u'^2} = \int_a^b u'^2 P(u) du = \int_a^b (u - \bar{u})^2 P(u) du \quad (3.25)$$

The variance gives us a measure of how “wide” the pdf is. The quantity σ (i.e. the square root of the variance) is called the *root mean square* (rms) of u . So, the pdf in Fig. 3.2A has a higher rms than the pdf of Fig. 3.2B, even if the mean is the same. It is clear that the mean alone does not convey all the information about the signal: the behaviour of Fig. 3.2A is very different from the behaviour of Fig. 3.2B.

The source term problem revisited

(a) Let $y = \dot{w}(\phi) = -k\phi$, i.e. a first-order reaction. Then:

$$\bar{y} = \overline{\dot{w}(\phi)} = \int_a^b \dot{w}(\phi)P(\phi)d\phi = -\int_a^b k\phi P(\phi)d\phi = -k\bar{\phi}.$$

(b) Let $y = \dot{w}(\phi) = -k\phi^2$, i.e. a second-order reaction. Then:

$$\begin{aligned}\bar{y} &= \overline{\dot{w}(\phi)} = \int_a^b \dot{w}(\phi)P(\phi)d\phi = -\int_a^b k\phi^2 P(\phi)d\phi = -k \int_a^b (\bar{\phi} + \phi')^2 P(\phi)d\phi \\ &= -k \int_a^b (\bar{\phi}^2 + 2\bar{\phi}\phi' + \phi'^2)P(\phi)d\phi = -k\bar{\phi}^2 - k\overline{\phi'^2} = -k(\bar{\phi}^2 + \sigma_{\phi}^2)\end{aligned}$$

Therefore the mean reaction rate of a second-order reaction depends not only on the mean, but on the variance of the scalar as well (equivalently, on the width of the pdf). We recovered Eq. (3.19) for $A=B$.

Important conclusion for averages

If a function is non-linear, the mean of the function is not equal to the function of the mean. For the special case of the linear function, the mean of the function is always equal to the function of the mean. In other words, if $y = f(x)$, then $\bar{y} = \overline{f(x)} \neq f(\bar{x})$.

The importance of the fluctuations

Assume that the trace of Fig. 3.2 corresponds to the concentration of the pollutant SO_2 at a house located downwind of a chemical factory with aged scrubbers. Assume that the “safe” level of inhaling the pollutant is exactly at the mean value. Would you rather breathe from a plume resulting in a concentration following the curve of Fig. 3.2A or of Fig. 3.2B? Clearly, when the fluctuations are large, even if the mean value is deemed “safe”, the receptor is exposed often to high dosages of the pollutant. If the health effects after exposure are a very non-linear function of the pollutant concentration, then a regulation expressed only in terms of the mean value of the pollutant is not safe enough. This highlights the importance of Eq. (3.17), which gives the variance of the pollutant fluctuations.

Ideally, the whole pdf of pollution concentration should be considered in conjunction to the “threshold” level for safety. However, this is not done often, not least because there are no easy tools available to predict the whole pdf for a reacting scalar. A way that this can be achieved is through a Monte Carlo (stochastic) simulation and this will be presented in Chapter 5.

3.4 Multi-variate probability density functionsFundamental properties

The concepts above are readily generalised to many variables. Let ϕ_1 and ϕ_2 be random variables (e.g. turbulent reacting scalars) with random space variables η_1 and η_2 , (for the sake of

simplicity both taken to lie between a and b). Then the probability that $\eta_1 < \phi_1 < \eta_1 + \Delta\eta_1$ and $\eta_2 < \phi_2 < \eta_2 + \Delta\eta_2$, is given by $P(\eta_1, \eta_2)\Delta\eta_1\Delta\eta_2$ and $P(\eta_1, \eta_2)$ is called the *joint pdf*.

Normalization condition:

$$\int_a^b \int_a^b P(\phi_1, \phi_2) d\phi_1 d\phi_2 = 1 \quad (3.26)$$

Averages:

For any function y of ϕ_1 and ϕ_2 ,

$$\bar{y} = \overline{f(\phi_1, \phi_2)} = \int_a^b \int_a^b f(\phi_1, \phi_2) P(\phi_1, \phi_2) d\phi_1 d\phi_2 \quad (3.27)$$

Covariance and correlation coefficient

For the product of the two random variables, we have that

$$\begin{aligned} \overline{\phi_1 \phi_2} &= \int_a^b \int_a^b \phi_1 \phi_2 P(\phi_1, \phi_2) d\phi_1 d\phi_2 = \int_a^b \int_a^b (\bar{\phi}_1 + \phi'_1)(\bar{\phi}_2 + \phi'_2) P(\phi_1, \phi_2) d\phi_1 d\phi_2 \\ &= \bar{\phi}_1 \bar{\phi}_2 + \int_a^b \int_a^b \phi'_1 \phi'_2 P(\phi_1, \phi_2) d\phi_1 d\phi_2 = \bar{\phi}_1 \bar{\phi}_2 + \overline{\phi'_1 \phi'_2} \end{aligned} \quad (3.28)$$

fully consistent with the Reynolds decomposition technique. The quantity $\overline{\phi'_1 \phi'_2}$ is called the *covariance* and the quantity

$$\rho_{12} = \frac{\overline{\phi'_1 \phi'_2}}{\sqrt{\overline{\phi_1'^2} \overline{\phi_2'^2}}} = \frac{\overline{\phi'_1 \phi'_2}}{\sigma_1 \sigma_2} \quad (3.29)$$

is called the *correlation coefficient* between ϕ_1 and ϕ_2 (σ_1 and σ_2 are the rms of the respective variables). There is a fundamental inequality in probability theory called the Cauchy-Schwartz inequality that states that always $-1 \leq \rho_{12} \leq 1$.

The concept of correlation coefficient is very important for understanding how the fluctuations of one scalar are related to the fluctuations of another. If $\rho_{12} = 0$, then the scalars are *uncorrelated*. If $\rho_{12} = -1$, then the scalars are perfectly negatively correlated, while if $\rho_{12} = 1$ the scalars are perfectly positively correlated. A negative correlation coefficient means that when the fluctuation of ϕ_1 is positive (i.e. ϕ_1 is above its mean) the fluctuation of ϕ_2 is negative (i.e. ϕ_2 is below its mean) and *vice versa*. A zero correlation, however, does not imply statistical independence.

Example

Let $y = \dot{w}_3 = k\phi_1\phi_2$ (i.e. the generation rate of product from the second-order reaction $\phi_1 + \phi_2 \rightarrow \phi_3$). Then:

$$\begin{aligned}\bar{y} = \overline{\dot{w}_3} &= \int_a^b \int_a^b \dot{w}(\phi_1, \phi_2) P(\phi_1, \phi_2) d\phi_1 d\phi_2 = \int_a^b \int_a^b k \phi_1 \phi_2 P(\phi_1, \phi_2) d\phi_1 d\phi_2 \\ &= k(\overline{\phi_1 \phi_2} + \overline{\phi_1' \phi_2'}) = k(\overline{\phi_1} \overline{\phi_2} + \rho_{12} \sigma_1 \sigma_2)\end{aligned}$$

We recovered Eq. (3.19). Therefore knowledge of the correlation coefficient and the variances of the two scalars can provide closure to the mean reaction rate term. All this information is, as we saw, contained in the joint pdf.

3.5 Typical pdf shapes in turbulent mixing

Gaussian distribution

Very often, turbulent quantities are assumed to follow the *Gaussian* or *normal* distribution. The corresponding probability density function is given by

$$P(\phi) = \frac{1}{\sqrt{2\pi}\sigma} \exp\left[-\frac{(\phi - \bar{\phi})^2}{2\sigma^2}\right] \quad (3.30)$$

So the mean $\bar{\phi}$ and the rms σ completely determine the shape of the pdf (Fig. 3.3). There are various points to note about this distribution:

- At very large or very small ϕ , the tails of the pdf approach zero asymptotically. Hence very large or very low values have finite (non-zero) probability, which makes this pdf, on first sight, inappropriate for *bounded* scalars.
- The peak of the pdf appears at the mean value $\bar{\phi}$.
- The width of the pdf is about 6σ . The probability of finding $\bar{\phi} - 3\sigma \leq \phi \leq \bar{\phi} + 3\sigma$ is about 99%.

This distribution is important not only in probability, but also in the plume dispersion problem (Chapter 4) and the comments above apply there as well.

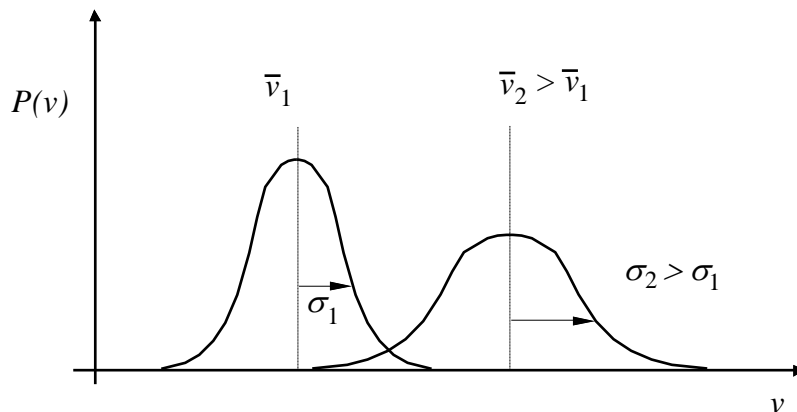

Figure 3.3 The normal (Gaussian) probability density function.

Jointly-Gaussian pdf

A usual shape for joint pdf's in turbulence is the jointly Gaussian or joint normal pdf (Fig. 3.4):

$$P(\phi_1, \phi_2) = \frac{1}{2\pi\sigma_1\sigma_2\sqrt{1-\rho_{12}^2}} \times \exp\left[-\frac{1}{(1-\rho_{12}^2)}\left(\frac{(\phi_1 - \bar{\phi}_1)^2}{2\sigma_1^2} - \frac{\rho_{12}(\phi_1 - \bar{\phi}_1)(\phi_2 - \bar{\phi}_2)}{\sigma_1\sigma_2} + \frac{(\phi_2 - \bar{\phi}_2)^2}{2\sigma_2^2}\right)\right] \quad (3.31)$$

We will encounter this equation again in Chapter 4 in the case of plume diffusion.

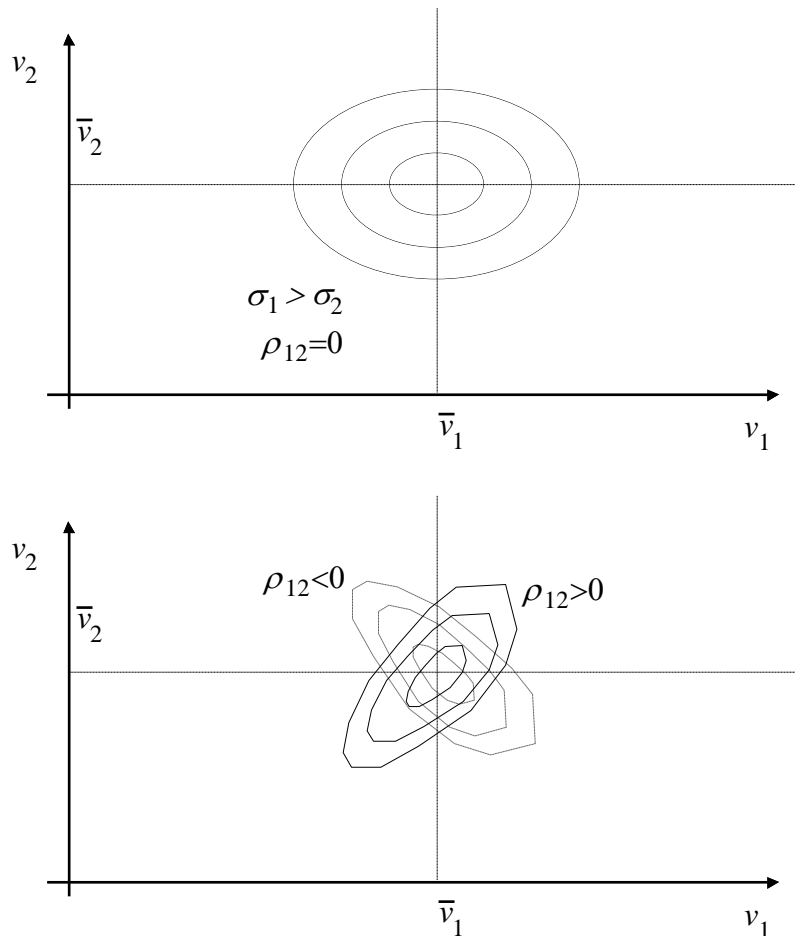

Figure 3.4 The joint normal probability density function for uncorrelated, positively and negatively correlated variables. Equal-probability contours are shown.

Uniform distribution

If ϕ is equally probable to take any value between a and b , then $P(\phi)$ is called the *uniform distribution* and the pdf is simply equal to $P(\phi) = 1/(b-a)$. In two dimensions and for uncorrelated variables, $P(\phi_1, \phi_2) = \frac{1}{(b_1 - a_1)} \frac{1}{(b_2 - a_2)}$. This situation is not very common in turbulence for a

scalar or the velocity. However, the uniform distribution is extremely useful as an analytical tool because other distributions can be related to it.

Bounded pdfs

In many situations of interest, the scalar is bounded. For example, if ϕ corresponds to a concentration of pollutant in air, it cannot be less than zero nor higher than the maximum value it had at the source. In this case, $a=0$ and $b=\phi_{\max}$. The pdf should, strictly speaking, be represented by an expression that reflects this bounded character.

Various techniques to achieve this have been proposed. One is to use a “clipped Gaussian distribution”, where delta functions of variable strengths are used at the extrema points (a and b). Another is to use the so-called “beta function pdf”. Both have been used in turbulent reacting flows, but are analytically complex to represent. Qualitative shapes of pdfs for inert scalars corresponding to a typical mixing flow are given in Fig. 3.5. For a deeper discussion, see Bilger (1980).

Pdfs of reactive scalars

Unfortunately, the chemical reaction *changes* the shape of the pdf in an unknown way. Hence, no simple shape can be provided. The situation is even worse for the joint pdf of two reactive scalars. However, there are methods by which the joint scalar pdf can be *numerically* evaluated. It is evident from Eqs. (3.19) or (3.28) that knowledge of the shape of the joint pdf is sufficient to close the turbulent reacting flow problem, and hence a lot of research emphasis has been put in developing such methods (Pope, 2000). We will present a very simplified but still powerful technique for estimating the statistics of random phenomena in Chapter 5.

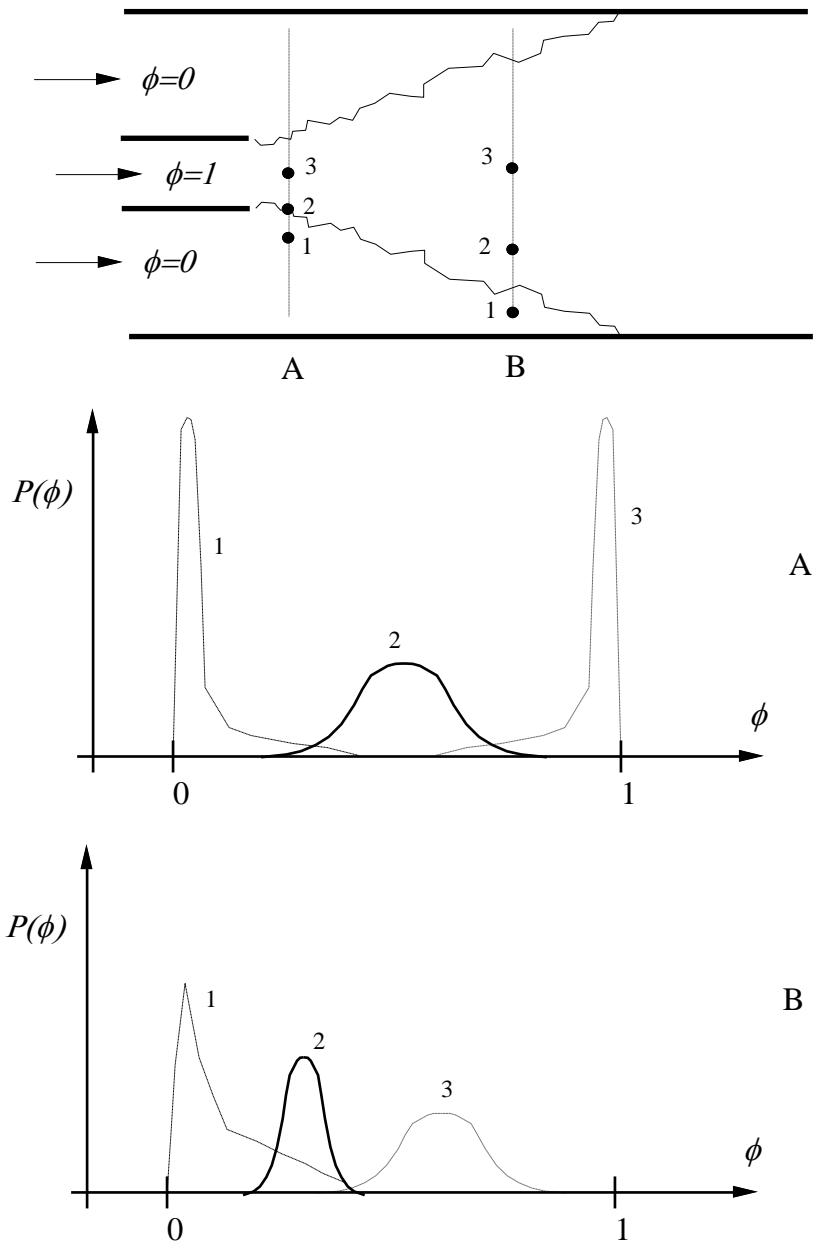

Figure 3.5 Pdf shapes of a bounded inert scalar for a typical turbulent mixing flow.

3.6 Worked examples

Example 3.1

Show that the average of a linear function is equal to the function of the average.

Solution

Let $y = f(x) = A + Bx$. Then:

$$\bar{y} = \overline{f(x)} = \int_a^b f(x)P(x)dx = \int_a^b (A + Bx)P(x)dx = A \int_a^b P(x)dx + B \int_a^b xP(x)dx = A + B\bar{x} = f(\bar{x})$$

Example 3.2

Assume that the concentrations of NO and O₃ measured one day are uncorrelated and obey a joint uniform density function, with both pollutants taking values between 0 and 40 ppb. Calculate the probability that both pollutants exceed 30 ppb.

Solution

The required probability is $\int_{30}^{40} \int_{30}^{40} \frac{1}{(40-0)(40-0)} d\phi_1 d\phi_2 = \frac{1}{16}$. Alternatively, we can solve

this graphically. Since both variables have the same extreme values (same sample space) and are uncorrelated, the joint uniform distribution will look like a square (see below). The probability that both pollutants exceed a given value is given by the area of the shaded square, which is equal to $1/4 \times 1/4 = 1/16$ (since the area of the whole rectangle is unity, by the normalization condition). The same concept can be used for more relevant pdf shapes (e.g. normal distribution), but then the calculation of the probability necessitates resort to tables that tabulate values of the integral of the Gaussian.

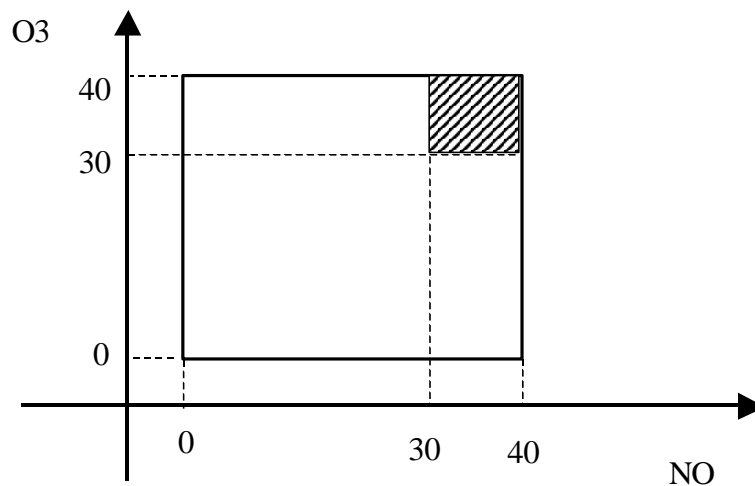

4. Air Quality Modelling and plume dispersion

In this Chapter, we will discuss in detail some of the tools used currently in predicting the dispersion of pollutants in the atmospheric environment. We begin from the simplest method, the box model, and we proceed to the paradigm problem of plume dispersion. We emphasize the practical applications and future directions of Air Quality Modelling.

4.1 Box models

Basic idea

Consider Fig. 4.1, where we have enclosed a whole city in a control volume. Assume that the air in the box is *fully uniform* in concentration and that there is uniform wind of velocity U flowing along the x -direction. Assume that the box extends up to the mixing height H . Assume that there is background pollution b (a convenient and common unit is in kg of pollutant per m^3 of air) that is being advected towards the city by the wind and that the city itself generates q $\text{kg}/\text{m}^2/\text{s}$ of the pollutant. Then, the conservation of mass for this pollutant gives for its concentration c in the box (in the same units as b):

$$WLH \frac{dc}{dt} = UWHb - UWHc + qWL + WHL\dot{w}_c \quad (4.1)$$

$$\Leftrightarrow \frac{dc}{dt} = (b - c) \frac{U}{L} + \frac{q}{H} + \dot{w}_c \quad (4.2)$$

The l.h.s. of Eq. (4.1) is the unsteady accumulation of the pollutant. The first term on the r.h.s. is the amount of pollutant advected *into* the box by the wind; the second term is the amount advected *out* of the box (note that what is being advected out has concentration c , the concentration of the well-mixed box); the third term shows how much c per unit time is released in the city (e.g. by factories or cars); the last denotes how much c is being generated by chemical reactions (e.g. by transformations from other pollutants). The reaction rate \dot{w}_c has units kg of pollutant per unit volume.

Very often we are interested only in the steady state, i.e. $dc/dt=0$. Let us also neglect reactions, which is a good approximation if the particular pollutant reacts very slowly compared to the residence time L/U . Then, Eq. (4.2) gives that the pollutant will be in a concentration c_{bm} above the city, given by

$$c_{bm} = b + \frac{qL}{UH} \quad (4.3)$$

This is the “standard” box model result used in Air Quality Modelling practice and hence the subscript bm in Eq. (4.3).

Equation (4.3) involves many assumptions, the most important of which are that the pollutant is uniformly distributed in the box, that the wind is uniform (despite the boundary layer!), and that the emission is uniformly distributed across the area of the city. Clearly, none of these assumptions is really justified. Nevertheless, Eq. (4.3) shows the correct scaling with H and U : low mixing heights and low winds imply a higher concentration of pollutant. Note also that the local city meteorology affects the pollution concentration through the wind U and the mixing height H . Hence we expect a larger concentration of pollutant at night (small H , small U) than at day, although this may be counterbalanced by the higher emissions during daytime (e.g. from traffic).

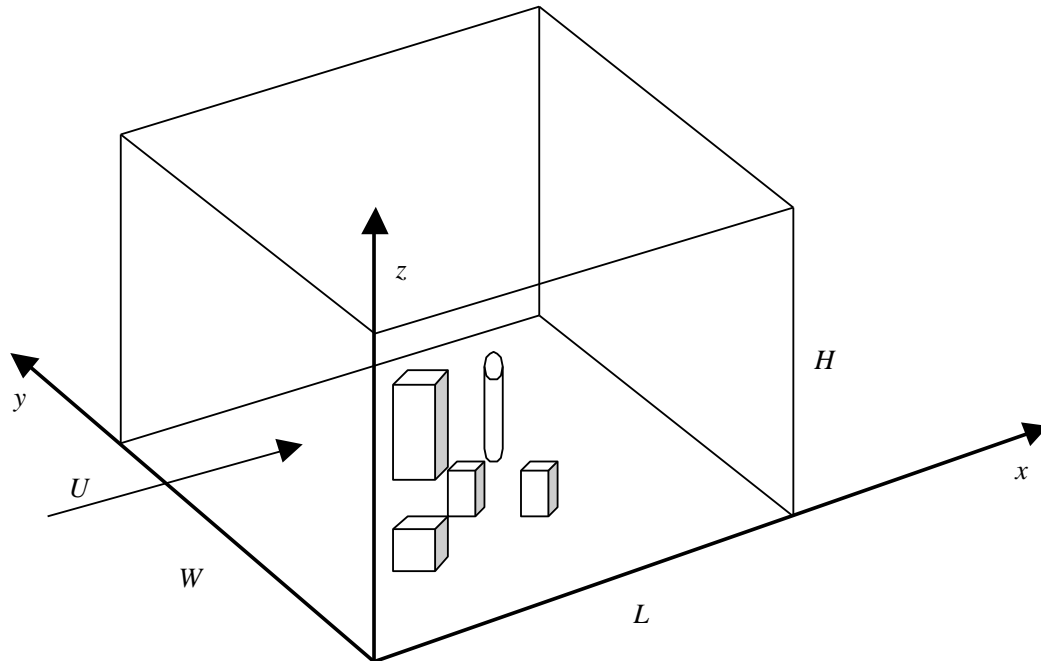

Figure 4.1 A typical city box model. By convention, we take the x -direction aligned with the wind.

Further applications

Emphasis on chemistry

Equation (4.2) is not restricted to a single pollutant. Various researchers use it for examining also the chemistry and emphasize the reaction rate term, rather than the wind transport. In such box models, the governing equation for each species i becomes

$$\frac{dc_i}{dt} = \dot{w}_i \quad (4.4)$$

Equation (4.4) is solved by numerical methods subject to a particular set of initial conditions and the solutions can help identify how the various pollutants are transformed during the day. Comparisons with experimental data can then assist in developing chemical mechanisms, such as “tuning” the rates of the various reactions like the smog-forming reactions R-II to R-IV in Chapter 2. Developing detailed chemical mechanisms for atmospheric pollution is a very active research area at present, not least because more and more chemicals come under regulation.

Emphasis on inhomogeneity

It is not a bad assumption to take the pollutant concentration as uniform in the z -direction, especially during unstable stratification. However, the assumption of homogeneous concentration in

the wind direction is usually much worse because often q is a function of x . This can be partly dealt with by re-deriving Eq. (4.2) for a thin strip of thickness Δx and hence obtaining a differential equation for dc/dx . (The derivation is given as an exercise in the Examples Paper. See also Example 4.2.)

Emphasis on yearly averages

Very common in Air Quality Modelling, Eq. (4.3) is used for a range of wind directions and speeds and a range of mixing heights, so that various meteorological conditions can be examined to find the corresponding pollutant concentrations. These are then weighted by the probability of occurrence of these particular conditions and hence a yearly average pollutant concentration can be calculated. Such calculations are important, e.g. for planning anti-pollution measures, for calculating the extra environmental burden of new industrial plants, etc.

4.2 Gaussian dispersion models

Model problem

The paradigm problem concerning pollution relatively close (e.g. a few km) to a source is the “*chimney plume*”. This is shown on Fig. 4.2. We are interested in: (a) the width of the plume downwind; (b) the concentration of the pollutant across the plume and particularly on the ground; (c) the difference between a steady emission (a “*plume*”) and an unsteady emission (a “*puff*”). To calculate these items is very important from a practical point of view and forms the topic of this Section. The material in this Section is based mostly on De Nevers (1995) and Csanady (1973).

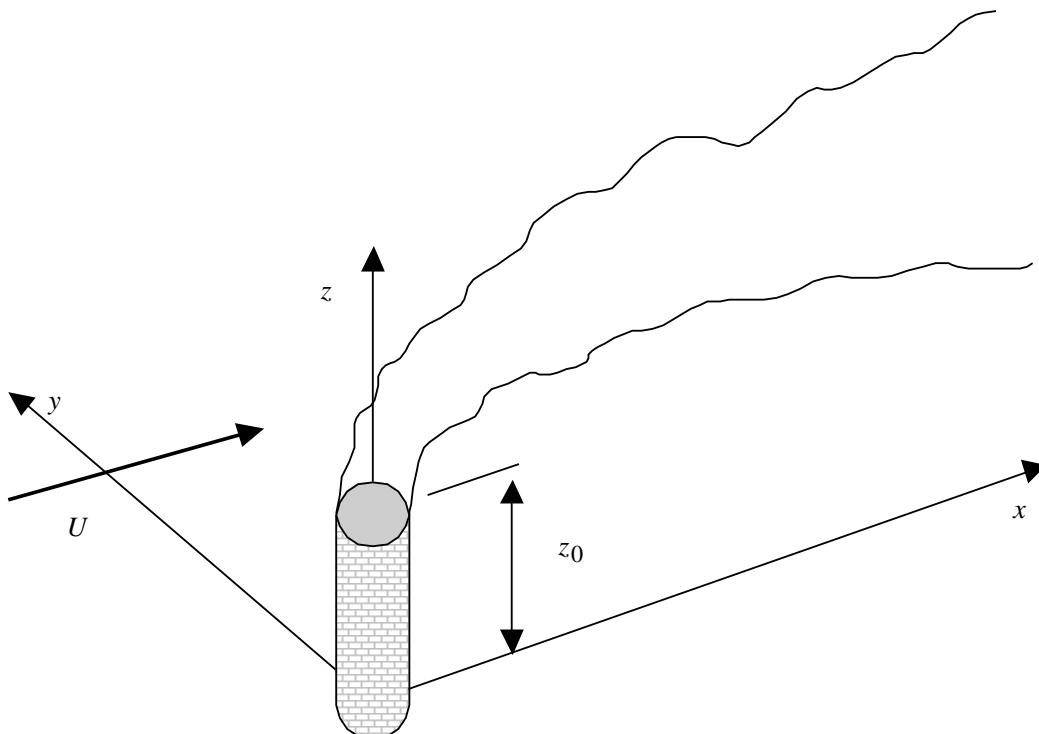

Figure 4.2 A typical chimney plume, showing the definition of the quantities used in the analysis.

Turbulent diffusion of an unsteady puff

Derivation

In many cases, we are interested in the way a pollutant spreads under the action of turbulent diffusion, when the emission of the pollutant is not continuous, but occurs only for a short time. Our full governing equation (Eq. 3.12) is our starting point, but to demonstrate how the solution comes about, let us assume zero mean velocities and finite and spatially-uniform turbulent diffusivity. Then, Eq. (3.12) becomes:

$$\frac{\partial \bar{\phi}}{\partial t} = K_j \frac{\partial^2 \bar{\phi}}{\partial x_j^2} + \bar{w} \quad (4.5)$$

The overbar denotes the mean concentration of the pollutant and the eddy diffusivity is now allowed to *be a function of the direction*. This is usually the case in atmospheric turbulence: the velocity fluctuations are not really equal in the three directions, and hence the eddy viscosity is strictly speaking a (diagonal) tensor. Hence the appearance of the subscript j in K in Eq. (4.5). We have also denoted the turbulent diffusivity by the symbol K (rather than D_T) to conform to the standard notation in atmospheric pollution.

For an inert pollutant, Eq. (4.5) is identical to the unsteady heat conduction equation for an “instantaneous source” and has a known solution. If Q kg/s of pollutant are released over a (very short) time Δt at point (x_0, y_0, z_0) , the solution of Eq. (4.5) gives for the mean pollutant concentration $\bar{\phi}$ in one, two, and three dimensions (in kg/m, kg/m², kg/m³ respectively):

$$\bar{\phi}(x) = \frac{Q\Delta t}{2(\pi)^{1/2}(K_x)^{1/2}} \exp\left[-\frac{1}{4t} \frac{(x-x_0)^2}{K_x}\right] \quad (4.6)$$

$$\bar{\phi}(x, y) = \frac{Q\Delta t}{4(\pi)(K_x K_y)^{1/2}} \exp\left[-\frac{1}{4t} \left(\frac{(x-x_0)^2}{K_x} + \frac{(y-y_0)^2}{K_y}\right)\right] \quad (4.7)$$

$$\bar{\phi}(x, y, z) = \frac{Q\Delta t}{8(\pi)^{3/2}(K_x K_y K_z)^{1/2}} \exp\left[-\frac{1}{4t} \left(\frac{(x-x_0)^2}{K_x} + \frac{(y-y_0)^2}{K_y} + \frac{(z-z_0)^2}{K_z}\right)\right] \quad (4.8)$$

where t is the time from the release. Note the “symmetry” of the terms in the exponential, but also note that the behaviour of the maximum concentration at the centre of the cloud (i.e. at x_0, y_0, z_0) has a different scaling with time depending on the dimensionality of the problem.

In practical atmospheric dispersion of pollutant clouds, the wind has to be taken into account. The situation is visualized in Fig. 4.3. The governing equation becomes (for an inert pollutant)

$$\frac{\partial \bar{\phi}}{\partial t} + U \frac{\partial \bar{\phi}}{\partial x} = K_x \frac{\partial^2 \bar{\phi}}{\partial x^2} + K_y \frac{\partial^2 \bar{\phi}}{\partial y^2} + K_z \frac{\partial^2 \bar{\phi}}{\partial z^2} \quad (4.9)$$

The solution of Eq. (4.9) is again Eq. (4.8), but now we must interpret the time t as the downwind distance X of the *centre of the pollutant cloud*, divided by the wind speed U , and x, y, z as the distances from the centre of the cloud. In Eulerian coordinates (more useful!), x should be replaced

by $(x-X)$, with $X=Ut$. Usually, the coordinate system we use has an origin immediately underneath the release point on the ground (i.e. $x_0=y_0=0$) (Fig. 4.3) and so the “standard” form of the solution of Eq. (4.9) reads:

$$\bar{\phi}(x, y, z) = \frac{Q\Delta t}{8(\pi t)^{3/2}(K_x K_y K_z)^{1/2}} \exp\left[-\frac{1}{4t}\left(\frac{(x-Ut)^2}{K_x} + \frac{y^2}{K_y} + \frac{(z-z_0)^2}{K_z}\right)\right] \quad (4.10)$$

Depending on the relative magnitude of the K 's, the cloud may take a spherical or ellipsoidal or even a disk-like shape.

Final equation

Very often in atmospheric dispersion, we do not use the eddy diffusivities directly, but we work with the *dispersion coefficients*, defined by:

$$\sigma_x^2 = 2\frac{X}{U}K_x, \quad \sigma_y^2 = 2\frac{X}{U}K_y, \quad \sigma_z^2 = 2\frac{X}{U}K_z \quad (4.11)$$

Using the dispersion coefficients (units: m), Eq. (4.10) becomes

$$\bar{\phi}(x, y, z, t) = \frac{Q\Delta t}{(2\pi)^{3/2}\sigma_x\sigma_y\sigma_z} \exp\left[-\left(\frac{(x-Ut)^2}{2\sigma_x^2} + \frac{y^2}{2\sigma_y^2} + \frac{(z-z_0)^2}{2\sigma_z^2}\right)\right] \quad (4.12)$$

which is a “standard” Gaussian expression. The dispersion coefficients are usually functions of X and we will present empirical data for their values in sub-section 4.3. It is important to note that Eq. (4.12) is valid even if the eddy diffusivities K are not constant. This would be the case for short times from the release because then the constant eddy diffusivity idea breaks down: for small cloud widths, the pollutant is being dispersed by the action of only a small range of the turbulent eddies. This makes the diffusivity a function of time, until the cloud becomes large relative to the turbulence lengthscale. In atmospheric problems, this is hardly ever achieved and the dispersion coefficients in the above equations must be provided empirically.

Equation (4.10) (or Eq. 4.12) is called the “*Gaussian puff equation*” and is very useful in providing numerical estimates on the average amount of pollutant reaching a given point at a given time after a release. Such estimates are crucial for assessing the danger after accidents, such as the Chernobyl nuclear disaster or chemical releases. They are also used to assess the origin of the pollutant, given a set of measurements of the pollutant concentration at a particular point and the meteorological conditions prevailing at that time.

Cloud width

Another use of Eq. (4.12) is to find the width of the cloud. This can be defined in various ways, since the concentration reaches zero asymptotically towards the edge of the cloud. A common way is to use the length $\sqrt{2\sigma_y^2} = 2\sqrt{K_y X/U}$ as a characteristic half-width of the Gaussian cloud in the y -direction and similarly for the other directions. This length marks the location from the cloud centre where the concentration falls to $1/e$ of the centre value.

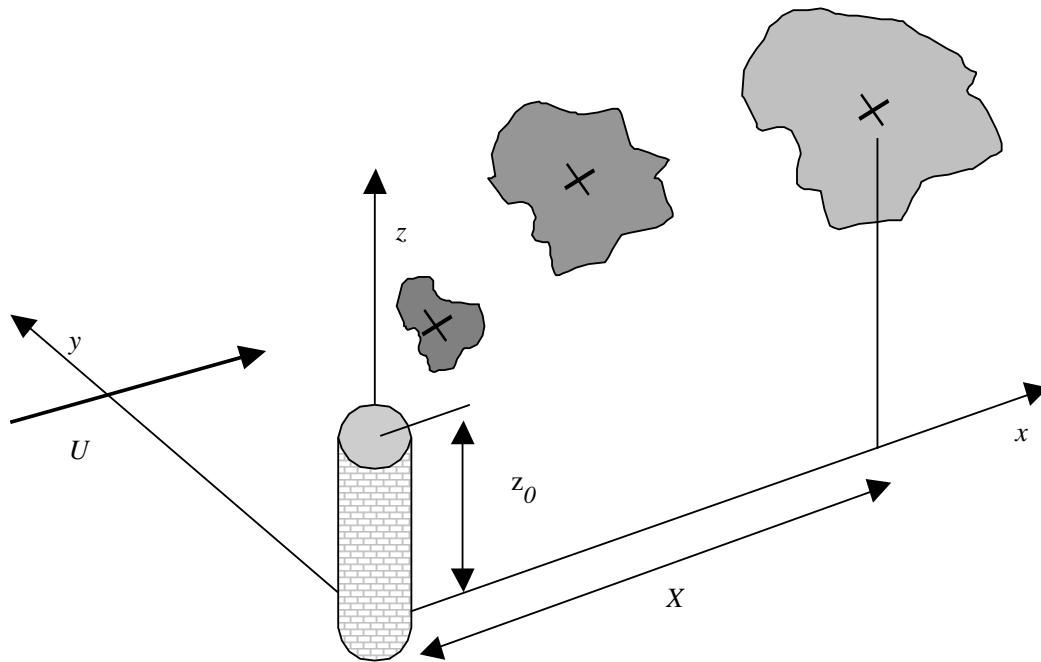

Figure 4.3 A typical pollution puff, showing the definition of the quantities used in the analysis.

Turbulent diffusion of a steady plume

Derivation

One way to understand the continuous emission from a chimney (Fig. 4.2) is to view it as a series of “instantaneous puffs”. Based on the linearity of Eq. (4.9), the overall concentration $\bar{\phi}$ downwind would be the sum over all such puffs. Assume then that the chimney continuously releases Q kg/s of pollutant and we use $t=x/U$. We are interested in the pollutant concentration at a particular point (x,y,z) at time t . Equation (4.12) can be integrated over time, to give the mean concentration due to a continuous source:

$$\bar{\phi}(x, y, z) = \frac{Q}{(2\pi)^{3/2}} \int_0^{\infty} \exp \left[- \left(\frac{(x-Ut')^2}{2\sigma_x^2} + \frac{y^2}{2\sigma_y^2} + \frac{(z-z_0)^2}{2\sigma_z^2} \right) \right] \frac{1}{\sigma_x \sigma_y \sigma_z} dt' \quad (4.13)$$

It is important to remember that we are now dealing with diffusion at *early times*, i.e. we are interested in the region close (e.g. of the order of 10^1 to 10^4 m) to the plume source. There, the width of the plume is clearly not much greater than the turbulence lengthscale, which is one of the conditions for validity of the constant eddy diffusivity. For short distances from the source, it turns out that the dispersion coefficients are proportional to time:

$$\sigma_x = u't, \quad \sigma_y = v't, \quad \sigma_z = w't \quad (4.14)$$

where u' , v' , w' are the r.m.s. turbulent velocities in the three directions, assumed constant. Equation (4.13) can then be integrated (after a very long and difficult procedure) to give:

$$\bar{\phi}(x, y, z) = \frac{Q}{(2\pi)^{3/2}} \frac{u'}{v'w'r^2} \exp\left(-\frac{U^2}{2u'^2}\right) \left[1 + \sqrt{\frac{\pi}{2}} \frac{Ux}{u'r} \exp\left(\frac{U^2 x^2}{2u'^2 r^2}\right) \operatorname{erfc}\left(-\frac{1}{\sqrt{2}} \frac{Ux}{u'r}\right) \right] \quad (4.15)$$

with $r^2 = x^2 + \frac{u'^2}{v'^2} y^2 + \frac{u'^2}{w'^2} (z - z_0)^2$. Usually, the plume is *slender*, which implies that $r \approx x$, and usually $u'/U = o(0.1) \ll 1$. Both these assumptions are used to simplify Eq. (4.15) into:

$$\bar{\phi}(x, y, z) = \frac{Q}{2\pi U \sigma_y \sigma_z} \exp\left[-\left(\frac{y^2}{2\sigma_y^2} + \frac{(z - z_0)^2}{2\sigma_z^2}\right)\right] \quad (4.16)$$

This is our final result for the plume diffusion problem and is one of the most important equations in this set of Lectures. It is often called the “*Gaussian plume equation*”. The x -dependence comes indirectly through the dependence of the dispersion coefficients on x , while the dependence on y and z comes directly from the exponential.

Diffusion from a point source

The slender plume approximation is equivalent to neglecting the axial diffusion because, compared to the advection, it causes little spreading. Equation (4.16) is also the solution of the general governing equation for a statistically-steady inert scalar being injected at a rate Q at point $(0,0,z_0)$, with x -wise diffusion neglected:

$$U \frac{\partial \bar{\phi}}{\partial x} = K_y \frac{\partial^2 \bar{\phi}}{\partial y^2} + K_z \frac{\partial^2 \bar{\phi}}{\partial z^2}$$

This problem is also known as “*diffusion from a point source*” and its solution is Eq. (4.16), with $K_y = \frac{U}{2} \frac{d\sigma_y^2}{dx}$ and $K_z = \frac{U}{2} \frac{d\sigma_z^2}{dx}$. Experimentally, the K 's are found indirectly by measuring the concentration across the plume, applying Eq. (4.16) to the measured profiles, and hence evaluating σ . This has proven to be a very useful tool to understand atmospheric turbulence and dispersion. The eddy diffusivities so found are called “*apparent eddy diffusivities*”.

Short and long time diffusion

For short distances, we have that $K_y = v'^2 t = v'^2 x/U$, $K_z = w'^2 t = w'^2 x/U$, while for long distances from the source we obtain $K_y = v'^2 T_{L,y} = v' L_y$, $K_z = w'^2 T_{L,z} = w' L_z$, where $T_{L,y}$ is the Lagrangian autocorrelation time in the y -direction, L_y is an equivalent lengthscale, and similarly for the z -direction. Because in general $v' \neq w'$ and $T_{L,y} \neq T_{L,z}$, in general $K_y \neq K_z$. Equation (4.12) for the cloud and Eq. (4.16) for the plume turn out to be valid for both short and long time mixing, with the difference that the dispersion coefficients are a different function of x in the two cases. From Eqs. (4.11) and (4.14), the width of the plume increases linearly with x for short times, while it increases as $x^{1/2}$ for long times.

The difference between short and long-time diffusion is important for the theoretical study of turbulent mixing. If the release occurs at a length of the order of the Kolmogorov scale, then there is an additional, “very early” time regime, where the plume grows by the action of molecular motions, and there too, it grows as $x^{1/2}$, but with a molecular, rather than a turbulent, diffusivity appearing in the proportionality constant. This is irrelevant to atmospheric pollutant problems, as the emission lengthscale – the stack diameter – is much larger than the Kolmogorov scale.

The Gaussian

Equation (4.16) is identical to a joint Gaussian expression in Section 3.5, Eq. (3.31), with $\rho_{12}=0$. This is no coincidence: in order to derive Eq. (4.16) we have implicitly assumed that the turbulent motions in the two directions are uncorrelated. This would not be so if there were shear in the air flow, which would give rise to finite Reynolds stresses. The presence of Reynolds stresses would make a cross-section of the plume look skewed (c.f. Fig. 3.4) and Eq. (4.16) would need correction. This is often done for predicting dispersion in the atmospheric boundary layer, but is beyond the purposes of this course.

Self-similar solutions

There is an alternative way to derive Eq. (4.16). This is based on the concept of self-similarity, which is presented (for one-dimensional spreading) in the Appendix.

Measurements of the dispersion coefficients

In order to use Eq. (4.16) in practical applications, we need to know the dispersion coefficients σ_y and σ_z . These will be functions of downwind distance x and will also be unequal, since the characteristic turbulence velocities are expected to be different in the horizontal and vertical directions. Finally, we expect them to depend on atmospheric conditions: for stable conditions, the r.m.s. velocities are very low and hence the dispersion coefficients small; for unstable conditions, the turbulence is vigorous and we expect much larger dispersion coefficients. Measurements over a range of stability conditions give the results plotted in Fig. 4.4. Due to the complexity of atmospheric turbulence, the dispersion coefficients increase with x at a rate between 1 and 1/2, with the vertical dispersion coefficient increasing at a variable rate with x and the horizontal at about 0.9. The various curves correspond to various stability classifications, described in Table 4.1. From this Table and Fig. 4.4, the σ 's can be estimated at a given downwind distance and hence Eq. (4.16) can be applied to give the mean pollutant.

Table 4.1 Stability categories of Pasquill (adapted from De Nevers, 1995). A to F refer progressively from the very unstable to the very stable conditions, with D the neutral.

Wind speed at 10 m high (m/s)	Day			Night	
	Solar intensity			Overcast	Clear
	Strong	Moderate	Slight		
0-2	A	A-B	B	-	-
2-3	A-B	B	C	E	F
3-5	B	B-C	C	D	E
5-6	C	C-D	D	D	D
> 6	C	D	D	D	D

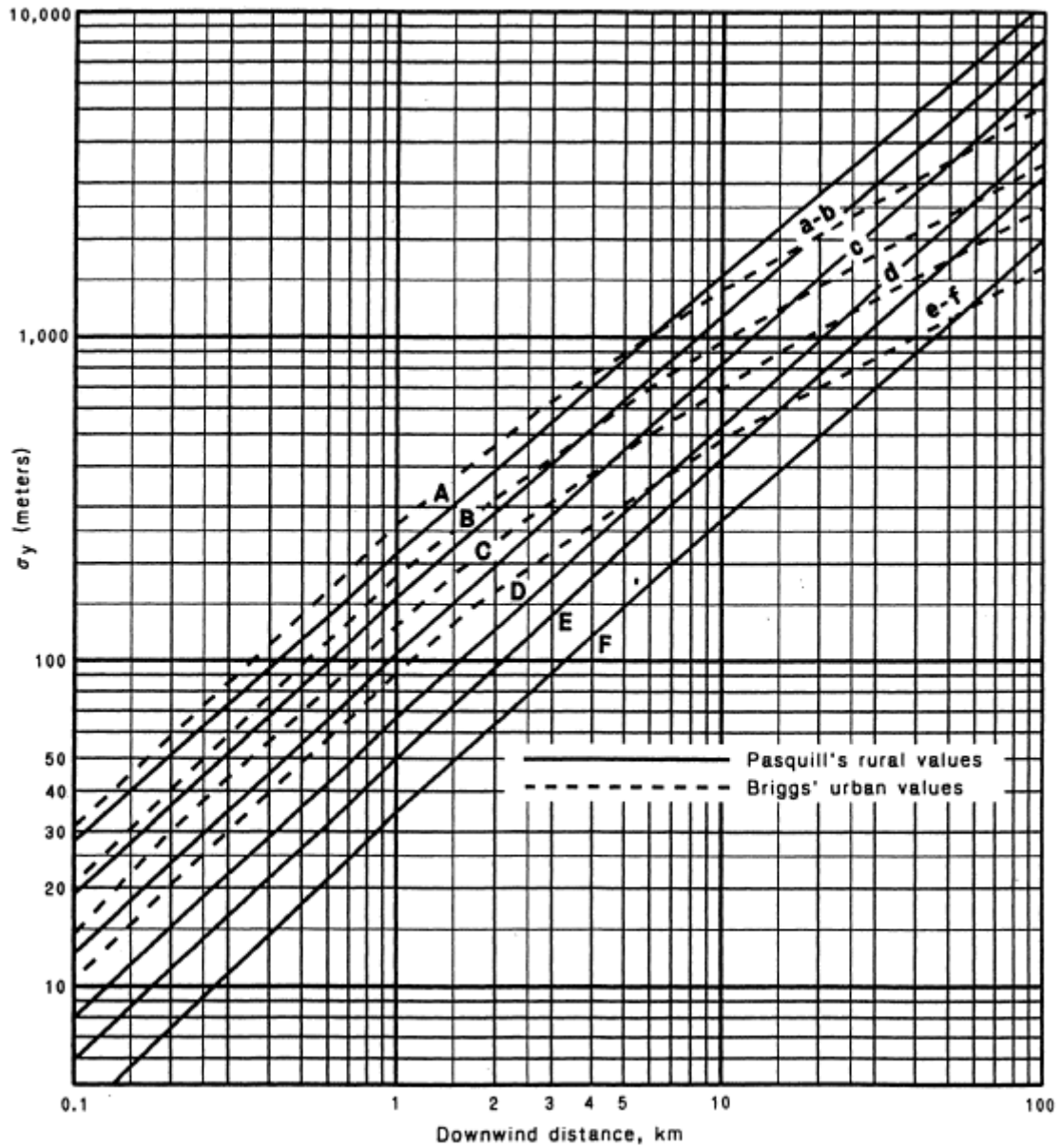

(a)

Figure 4.4 Horizontal (a) and vertical (b) dispersion coefficients as a function of downwind distance from the source for the “standard” stability conditions of Table 4.1 (De Nevers, 1995, quoting Turner).

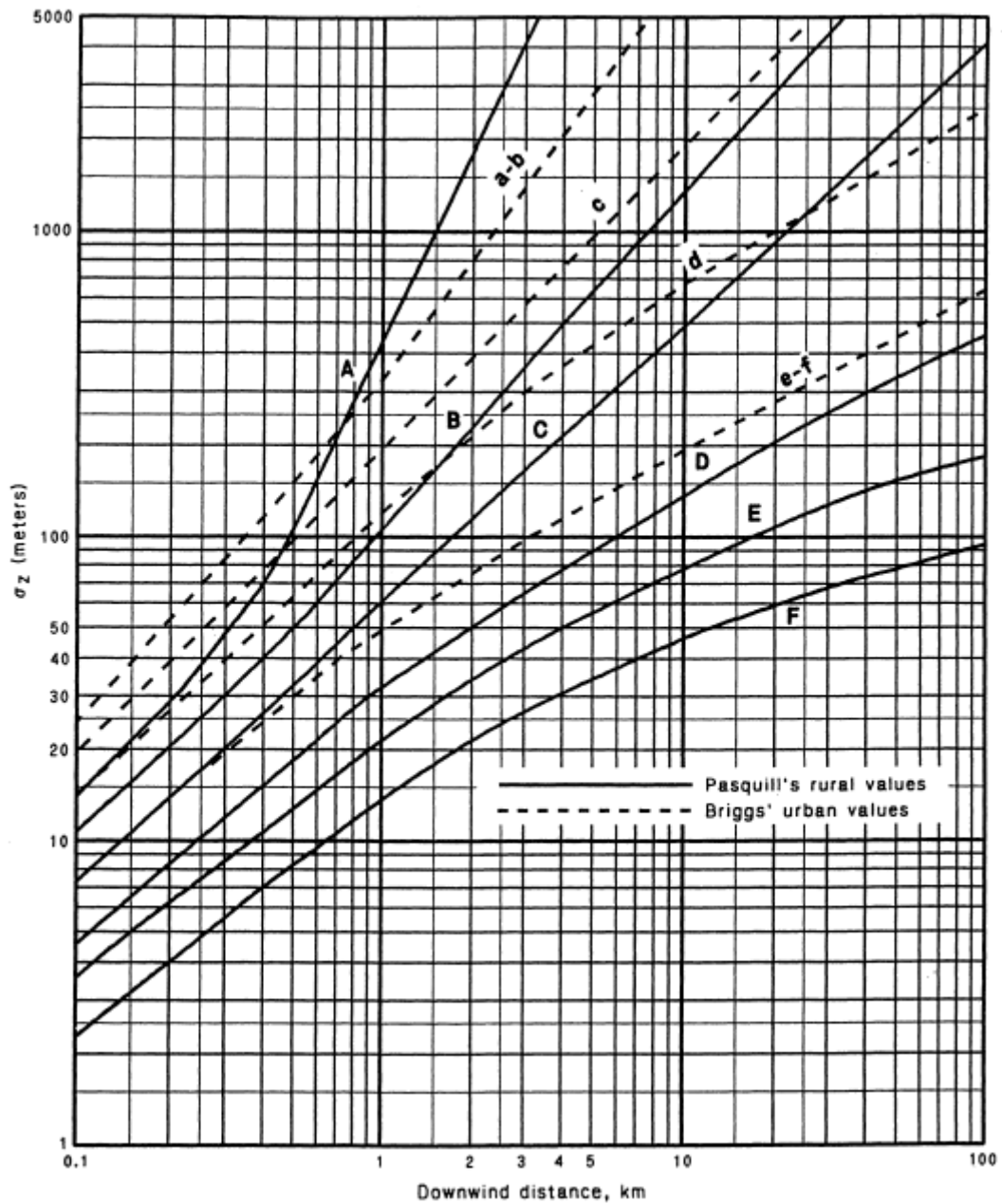

(b)

Figure 4.4 Cont'd.

Ground concentrations

One of the most important applications of the Gaussian plume equation is to calculate the pollutant concentration on the ground some distance downstream from the source. If the ground does not absorb any pollutant, then it “reflects” the pollutant reaching it. This is modelled by putting a “mirror image” source at $z = -z_0$, and then calculating at any point the combined effect of the two sources. Therefore, the Gaussian plume equation is modified to account for the ground effect as:

$$\bar{\phi}(x, y, z) = \frac{Q}{2\pi U \sigma_y \sigma_z} \left(\exp \left[- \left(\frac{y^2}{2\sigma_y^2} + \frac{(z-z_0)^2}{2\sigma_z^2} \right) \right] + \exp \left[- \left(\frac{y^2}{2\sigma_y^2} + \frac{(z+z_0)^2}{2\sigma_z^2} \right) \right] \right) \quad (4.17)$$

At $z=0$ (i.e. on the ground), the pollutant concentration is

$$\bar{\phi}(x, y, 0) = \frac{Q}{\pi U \sigma_y \sigma_z} \exp \left[- \left(\frac{y^2}{2\sigma_y^2} + \frac{z_0^2}{2\sigma_z^2} \right) \right] \quad (4.18)$$

and along the x -direction (the axis of the plume) on the ground we get

$$\bar{\phi}(x, 0, 0) = \frac{Q}{\pi U \sigma_y \sigma_z} \exp \left(- \frac{z_0^2}{2\sigma_z^2} \right) \quad (4.19)$$

Equation (4.19) is very useful for predicting the amount of pollutant (kg/m^3) reaching a receptor downwind from a pollution source emitting Q kg/s. It is used for assessing the environmental effects of various industrial plants etc. Note that the calculation depends crucially on the magnitude of the dispersion coefficients, and hence estimates such as those offered by Table 4.1 and Fig. 4.4 are very important for practical Air Quality Modelling.

When the ground is absorbing the pollutant, the image source idea can still be used, but now the image source must have a *negative* strength, i.e. the second exponential term in Eq. (4.17) should appear with a minus sign.

One-dimensional spreading

Diffusion in the vertical direction can occur only up to the mixing height H (Section 2.4). It happens often that the mixing height is low and then it does not take very long for the pollutant to become virtually homogeneously mixed in the vertical direction, but still diffusing in the horizontal direction. The horizontal concentration distribution in such cases will be given by:

$$\bar{\phi}(x, y) = \frac{Q}{UH} \frac{1}{\sqrt{2\pi}\sigma_y} \exp \left(- \frac{y^2}{2\sigma_y^2} \right) \quad (4.20)$$

which is useful and quite easy to remember. This equation is identical to the standard Gaussian, Eq. (3.30). From Eq. (4.20), we observe that the maximum concentration occurs at $y=0$ and is equal to $Q/(\sqrt{2\pi}UH\sigma_y)$.

Another problem where we have one-dimensional spreading is in “*diffusion from a line source*”. A motorway, for example, can be taken as a line source on the ground ($z_0=0$), emitting Q/L kg of pollutant per unit time and unit length. We usually take the source aligned with the y -axis and the wind with the x -axis. The pollution will be advected downwind and diffusion will occur in the vertical direction. The concentration profile in the vertical direction will be given by:

$$\bar{\phi}(x, z) = \frac{2Q}{UL} \frac{1}{\sqrt{2\pi}\sigma_z} \exp \left(- \frac{z^2}{2\sigma_z^2} \right) \quad (4.21)$$

with the x -dependence coming from the x -dependence of the dispersion coefficient (e.g. Fig. 4.4). Note that we still need an image line source, but now both sources coincide at $z_0=0$ (hence the 2 in the numerator). Equation (4.20) for the plume with vertical homogeneity is equivalent to diffusion from a vertical line source of strength Q/H , of course without any reflection since no boundaries exist normal to the y -direction.

Plume rise

Very often, the exhaust gases from chimneys are hotter than the environment or they have substantial momentum. This makes them rise and hence the release height z_0 that should be used in the Gaussian puff and plume equations does not correspond truly to the stack height h_s . Instead, it corresponds to the stack height plus the “*plume rise*” distance h_{pr} , which is the approximate height above the stack before the plume turns 90° to follow the wind. To predict buoyant plume rise theoretically would involve a combined examination of momentum and buoyancy in the curved plume and is a little involved. An empirical relationship used sometimes by engineers designing stacks is:

$$h_{pr} = \frac{V_s D}{U} \left[1.5 + 2.68 P D \frac{T_s - T_{atm}}{T_s} \right] \quad (4.22)$$

with h_{pr} the plume rise (m); V_s the stack exit velocity (m/s); D the stack diameter (m); P the pressure of the atmosphere (bar); and T_s and T_{atm} the temperatures of the stack gas and the atmosphere respectively (K).

4.3 Effects of local meteorology

Effect of inversions

We mentioned in Section 4.2 that the case of one-dimensional diffusion in the horizontal direction approximately corresponds to the case where the plume is perfectly mixed in the vertical direction. If the mixing height is higher than the source height, i.e. if $H > (h_s + h_{pr})$, then there is every possibility that the plume will hit the inversion lid from below, from where it will be reflected downward etc. This situation is shown in Fig. 4.5, which also demonstrates how the image source idea can be used to account for the mixing height. It is clear that the vertical direction will eventually become quite homogeneous.

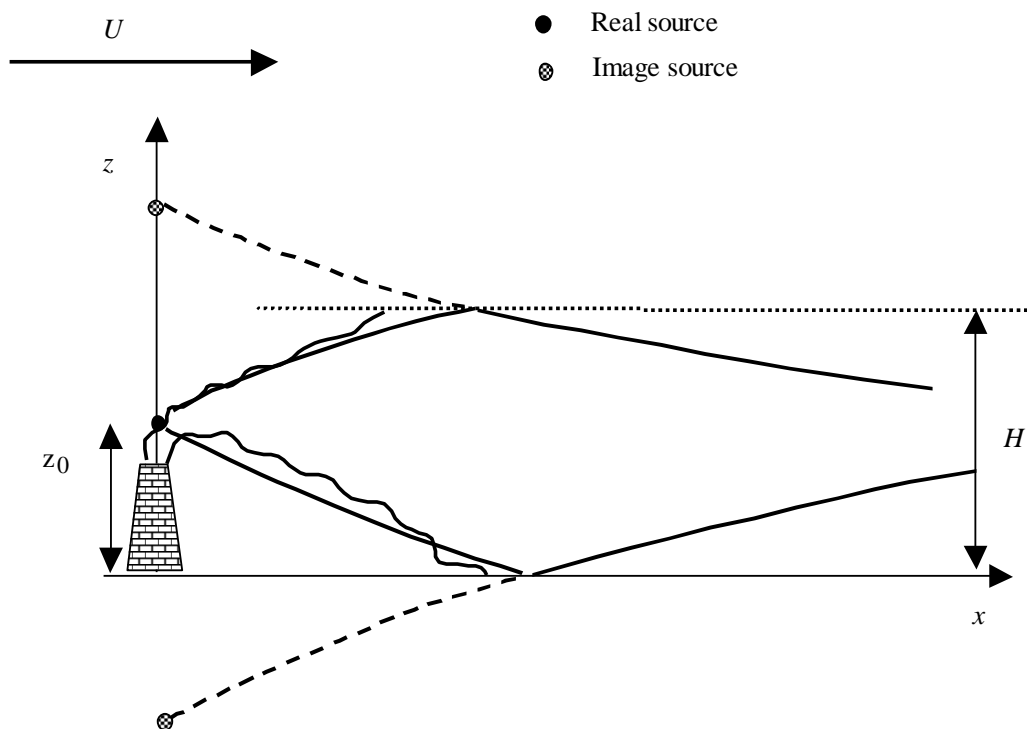

Figure 4.5 Effect of inversion lids on diffusion from a source below the inversion.

Equation (4.20) applies in this case for distances far enough from the source. Since vertical diffusion is eliminated, the ground concentration decays as x^{-1} (since, approximately, $\sigma_y \sim x^1$; Fig. 4.4), in contrast to a faster decay if the diffusion were two-dimensional (in the 2-D case, from Eq. 4.19 the maximum ground concentration decays by an additional σ_z^{-1}). Therefore, low mixing heights will result in higher ground concentrations.

Inversions assist in “trapping” pollution above a city, which can be thought as composed of a very large number of point sources. Cities with serious smog problems like Los Angeles, Athens, Istanbul and others, are located in sunny regions, bounded by mountains, and are close to the sea. In addition to more intense photochemistry, these conditions are favourable for the creation of inversion lids and hence such cities encounter high levels of pollution often.

Plume shapes

Depending on the conditions close to the plume source, the plume may acquire shapes very different from the “regular” diffusion shape defined by Eqs. (4.16) (without ground effect) and (4.17) (with ground effect). Various plume shapes and associated phenomena are described next and shown in Fig. 4.6.

Fumigation

If a plume is emitted into a very stable atmosphere (e.g. during a clear night), the plume travels downwind with very little dispersion. After dawn, as the sun heats the ground, an unstable layer is formed and the mixing height associated with the edge of this layer travels upwards as time

progresses. When this turbulent layer hits the plume, it causes very quick transport of the pollutant to the ground. This episode is called fumigation and it can result in very high ground concentrations, but for relatively short times.

Lofting

If either due to a very high stack or due to very high buoyant plume rise the plume source is effectively above the inversion, then the plume is dispersing upwards, but not downwards. The inversion acts like a solid boundary. This situation protects the ground receptor from high pollutant levels.

Fanning

If the plume source is within an inversion layer, it spreads horizontally but not vertically. This is called *fanning* and in such situations, the plume can travel long distances with little dilution.

Trapped plume

If the plume is below the inversion, it cannot penetrate it and the pollutant is not dispersing upwards. This causes higher ground concentrations than if the inversion were not there and is often the reason for high pollution levels in cities.

Downwash

Often it may happen that the stack sheds vortices or that the stack is in the wake of a large building. In both cases large eddies may trap the plume and push it towards the ground. These situations are called *downwash* or *flagging* and *downdraught* respectively. A rule of thumb by engineers is to use a stack height at least 2.5 times the height of the nearest building. Good aerodynamic design of the stack can help in reducing downwash. The same effect appears when the source is situated near a mountain, where the katabatic winds may not allow normal, Gaussian dispersion, but cause a bulk movement of the plume towards the ground. Katabatic winds also favour the creation of inversion lids by bringing cooler air close to the ground.

Looping

In very unstable situations, the eddies causing plume dispersion may be much larger than the plume width. This results in a “solid-body” motion of the plume, also called the “meandering plume”. See Section 5.3 for more discussion on this.

Thermalling

If the plume is very buoyant, it may break up in distinct parcels, as the plume itself is initiating thermals.

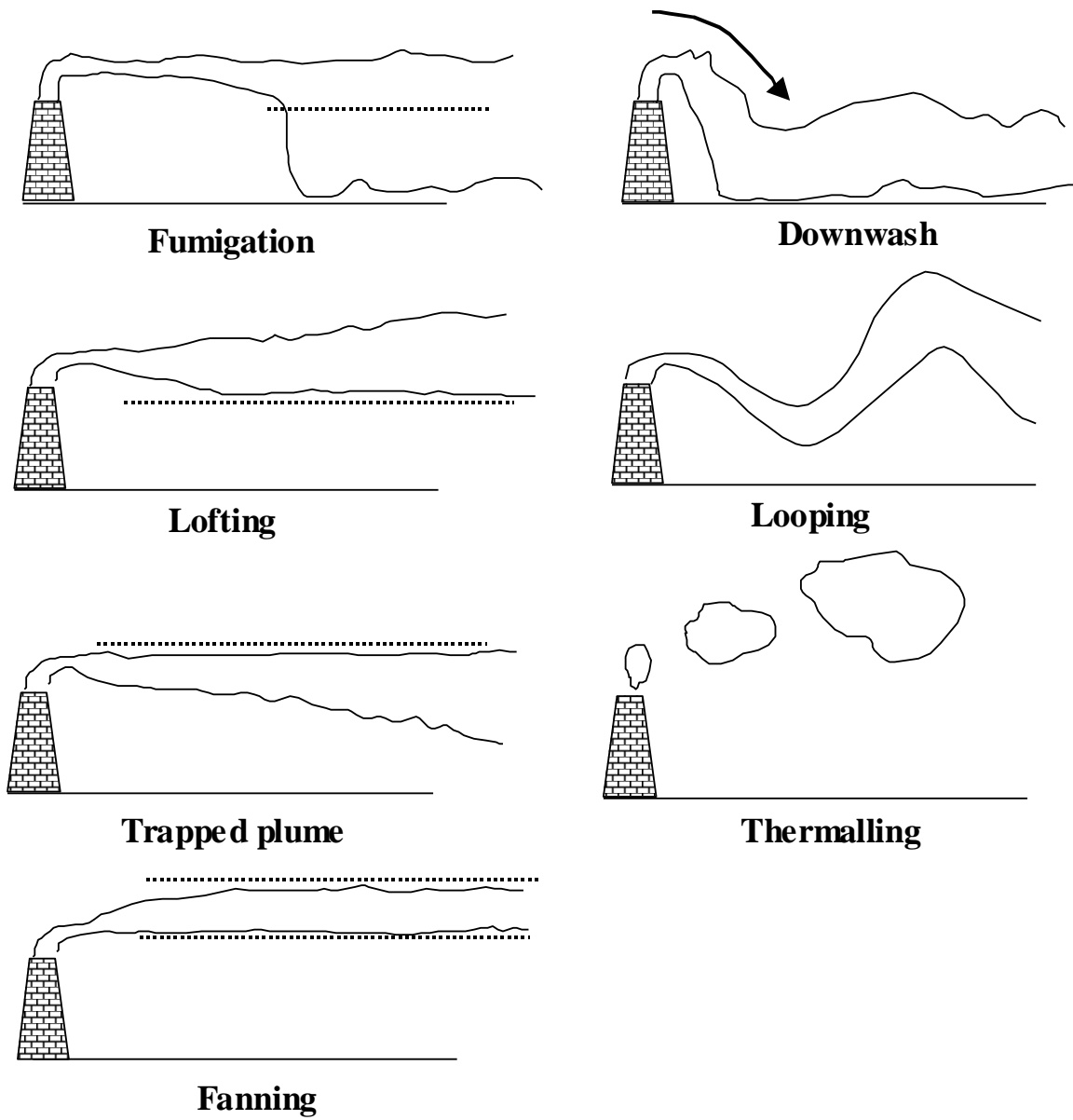

Figure 4.6 Some common plume shapes.

4.4 Practical Air Quality Modelling

In Section 4.2, we presented the “Box Model”, which is a very useful tool for estimating the pollution above a city. Such box models are used in scales of a few km. If one is interested in finer scales (e.g. a few hundred metres), and this may be imperative for accurate calculations of dosage, e.g. from a new industrial plant or a planned motorway, then we need to consider the dispersion very close to the source. For uniform wind conditions and well-defined sources, the Gaussian plume theory is approximately correct for up to a few tens of km, but eventually our assumption of constant wind will become invalid. For *synoptic scales*, i.e. longer than 200 km, we need to couple our pollution dispersion models with proper meteorological (i.e. weather prediction) codes.

Eulerian codes

In current practice, researchers solve Eq. (3.12), with proper attention to the chemistry and to phenomena such as deposition, aerosol formation, turbulence inhomogeneity and anisotropy, stratification etc. They do so after discretizing the p.d.e. on a grid of resolution applicable to the problem at hand. Because of this, they are also called “*grid models*”. The numerical techniques used are a very active research area. It is imperative that such codes can predict the evolution of pollutants from accidents or from a particular set of meteorological conditions in a short period of time (e.g. a few hours or days of CPU time), in order to be in a position to issue warnings about pollution episodes.

A serious scientific problem with Eq. (3.12) is how to model the chemical source term. This is still an unclosed issue and the current generation of codes use simply a mean reaction rate calculated from the mean species concentrations. We have seen in Section 3.2 and 3.3 that doing so is wrong, as it involves neglect of the species concentration fluctuations. In some cases, this is justified, as we will see in Ch. 5, but in many others, it is not.

The representation of the mean source term and of the turbulent diffusivity is the weakest points of practical AQM codes. In addition, the chemistry is not as well known as required to make very accurate predictions. AQM practitioners are happy to live with greater uncertainties than in other engineering fields.

Lagrangian codes

A different approach to track the dispersion and chemical evolution of pollutants is the so-called Lagrangian approach. Here, a large number of “fluid particles” is tracked in the synoptic scale weather motions and the chemistry of each of these particles is calculated with Eq. (4.4). Such calculations have shown, for example, the amount of radioactive material reaching Western Europe following the Chernobyl nuclear accident in 1986. They are also called “*trajectory models*”.

This approach has the advantage of having relatively low cost, but the accuracy of some of the assumptions used in early versions of this method is not very good, especially the modelling of the turbulent random walk experienced by the fluid as they disperse in the air. Despite this reservation, the idea of modelling the fluid as individual particles and then tracking the changes in each of these is a very useful one and the improvement of the accuracy of such models is a topic of research now.

The US Environmental Protection Agency Web Site

A series of links to the codes used in practical AQM can be found at the US EPA Web site: <http://www.epa.gov/scram001/tt22.htm#rec>

4.5 Worked examples

Example 4.1

A box model for a city has $W=5$ km, $L=15$ km, the mixing height is $H=1$ km, and the wind is blowing along the long dimension of the city with $U=5$ m/s. The background concentration of CO coming into the city is $b=5 \times 10^{-9}$ kg/m³, and the emission rate is $q=4 \times 10^{-9}$ kg/sm². Find the concentration of CO above the city.

Solution

This is a straightforward application of Eq. (4.3) and is intended to give an idea on the order of magnitude of the quantities used in conjunction with city box models. Putting numbers gives $c_{bm}=25 \times 10^{-9}$ kg/m³. Note that the result is independent of the width of the city.

Example 4.2

The worst assumption in the standard box model is that the concentration is uniformly distributed along the wind direction. By doing a mass balance on infinitesimally thin strips normal to the wind, the following o.d.e. can be derived for $c(x)$ (the derivation is given as an exercise in the Examples Paper): $Udc/dx = q(x)/H + \dot{w}$. Assume now that the pollutant undergoes photolysis, so that it is being destructed at a rate $\dot{w} = -kc$. Find $c(x)$ if q is constant and if no pollutant enters the city.

Solution

Since no pollutant enters the city, $c(0)=0$. Then, solving the o.d.e. gives:

$$U \frac{dc}{dx} = \frac{q(x)}{H} + \dot{w} \Leftrightarrow \frac{dc}{dx} = \frac{q}{UH} - \frac{k}{U}c \Leftrightarrow \frac{dc}{\frac{q}{UH} - \frac{k}{U}c} = dx \Leftrightarrow c(x) = \frac{q}{kH} \left[1 - \exp\left(-\frac{k}{U}x\right) \right]$$

Therefore, the concentration of c will become equal to q/kH at x long compared to U/k . If photolysis were absent ($k=0$), integrating the o.d.e. would give that $c=qx/UH$, i.e. the pollutant is continuously increasing with downwind distance and we recover Eq. (4.3) for $x=L$. Photolysis reactions and other removal mechanisms (e.g. deposition to ground by rain) are important in controlling the levels of atmospheric pollution.

Example 4.3

An accident in a chemical factory releases 1000 kg of SO₂ from a chimney. The pollutant cloud is assumed to rise vertically upwards very quickly and then it is transported horizontally by the wind blowing with 5 m/s. The three turbulent diffusivities are estimated as 100 m²/s. Estimate the width of the cloud 5 km downstream and the pollutant concentration at the centre of the cloud.

Solution

This is a straightforward application of Eq. (4.10). The concentration at the centre will be:

$$\bar{\phi}(X,0,z_0) = \frac{q}{8(\pi X/U)^{3/2}(K_x K_y K_z)^{1/2}}, \text{ with } q=1000 \text{ kg, } X=5 \text{ km, } K_x=K_y=K_z=100 \text{ m}^2/\text{s, and}$$

$U=5 \text{ m/s}$. The width of the cloud is estimated as $4\sqrt{KX/U}$ (since we want the total width). Putting numbers, we get that $\bar{\phi}_{\text{SO}_2} = 7.1 \times 10^{-7} \text{ kg/m}^3$ and the cloud width is 1265 m.

Example 4.4

The effluent stream in a refinery is at 1 bar and 300 K and flows at 10 m/s from a chimney of diameter of 200 mm. The exhaust gases contain 100 ppm (by mass) of VOC's and the chimney is 20 m high. Neglecting any plume rise, find the ground concentration 10 km downwind the refinery for the following conditions: (i) wind of 2.5 m/s at night on a clear night; (ii) wind of 8 m/s on a sunny day with strong sunlight. Calculate the horizontal width of the plume at this point. If the atmospheric temperature is 280K, is the assumption of negligible plume rise valid?

Solution

This is a straightforward application of Eq. (4.19). The mass flow rate of the pollutant at the source is $Q=(100 \times 10^{-6}) \times (10^5/287/300) \times (\pi 0.2^2/4) \times 10 \text{ kg/s} = 3.65 \times 10^{-5} \text{ kg/s}$. The dispersion coefficients for the given conditions at $x=10 \text{ km}$ are given from Table 4.1 and Fig. 4.4 as: (i) category F, so $\sigma_y=280 \text{ m}$ and $\sigma_z=50 \text{ m}$; (ii) Category C, so $\sigma_y=800 \text{ m}$ and $\sigma_z=530 \text{ m}$. Therefore, from Eq. (4.19), we obtain that the ground concentration is (i) $3.1 \times 10^{-10} \text{ kg/m}^3$ and (ii) $3.4 \times 10^{-12} \text{ kg/m}^3$.

The horizontal width of the plume at that location can be defined as twice the y -coordinate where the value of the pollutant is $1/e$ of its value along the centre. This occurs at $y^2 = 2\sigma_y^2$, which gives the overall width of the plume as 792 m for case (i) and 2263 m for case (ii). To calculate the plume rise, we use the empirical formula Eq. (4.22) which gives that $h_{pr}=1.34 \text{ m}$ for case (i) and 0.42 m for case (ii). Hence, we were justified to neglect it, more so for the strong wind case (ii).

This example demonstrates the major alterations to the plume dispersion process expected from a switch from stable to unstable stratification conditions.

Example 4.5

For the plume of Example 4.4, find the point immediately below the axis of the plume on the ground (i.e. $y=0, z=0$) that has the highest pollutant concentration. Assume that $\sigma_y = Ax^m$ and $\sigma_z = Bx^n$.

Solution

Differentiating Eq. (4.19) with respect to x and using the given variation of the dispersion coefficients with x , we get that $d\bar{\phi}(x,0,0)/dx = 0$ when $\frac{z_0^2}{2\sigma_z^2} = \frac{1}{2} + \frac{m}{2n}$. It is a reasonable

approximation to assume that m/n is not substantially different from unity. Hence, the maximum will occur when $\sigma_z = z_0/\sqrt{2}$. Putting numbers, the maximum concentration will occur when σ_z is 14.1 m. So reading from Fig. 4.4, for case (i), this will occur at a downwind distance of 1.5 km, while for case (ii), the maximum ground concentration will be at about 0.25 km. Note the very different behaviours between the two atmospheres, which shows the different possibilities between pollution dispersion during day and night at the same geographic location.

Appendix: An alternative derivation of the Gaussian plume equation

For simplicity of presentation, we will consider only one-dimensional spreading. Assume that Q kg/s are emitted over a line of length H parallel to the y -axis. There are no solid boundaries. The governing equation for the mean concentration then becomes

$$U \frac{\partial \bar{\phi}}{\partial x} = K \frac{\partial^2 \bar{\phi}}{\partial z^2} \quad (\text{A4.1})$$

which is identical to the unsteady heat equation if we recognize that $t=x/U$. Our initial and boundary conditions will determine the solution. Many solutions of Eq. (A4.1) are given in advanced heat transfer books. An alternative way to show the rationale behind the solution we used (Eq. 4.20), is to seek *self-similar* solutions. By “self-similar” we mean solutions that depend on one independent variable only, which is a combination of the two dependent variables t and z . Most slender turbulent flows are self-similar for the velocity and the scalar fields.

Let us say that we seek a function $f(\eta)$, such that

$$\bar{\phi} = \Phi_0 f(\eta) \quad (\text{A4.2})$$

$$\eta = z / \sigma \quad (\text{A4.3})$$

with Φ_0 and σ being a function of x only. The quantity Φ_0 is a characteristic scale of the concentration, while σ is a characteristic width of the plume, both as yet undetermined. We will use the following transformation rules:

$$\begin{aligned} \frac{\partial f}{\partial x} &= \frac{\partial f}{\partial \eta} \frac{\partial \eta}{\partial x} \\ \frac{\partial \bar{\phi}}{\partial z} &= \frac{\partial \bar{\phi}}{\partial \eta} \frac{1}{\sigma} \end{aligned}$$

and from Eq. (A4.3),

$$\frac{\partial \eta}{\partial x} = -\frac{\eta}{\sigma} \frac{\partial \sigma}{\partial x}$$

Using the above and substituting Eqs. (A4.2) and (A4.3) in (A4.1) gives:

$$\begin{aligned} \left(U \frac{d\Phi_0}{dx} \right) f + \left(-\frac{U\Phi_0}{\sigma} \frac{d\sigma}{dx} \right) \eta \frac{df}{d\eta} &= \left(\frac{K\Phi_0}{\sigma^2} \right) \frac{d^2 f}{d\eta^2} \Leftrightarrow \\ \frac{d^2 f}{d\eta^2} + \left(\frac{U\sigma}{K} \frac{d\sigma}{dx} \right) \eta \frac{df}{d\eta} - \left(\frac{U\sigma^2}{K\Phi_0} \frac{d\Phi_0}{dx} \right) f &= 0 \end{aligned} \quad (\text{A4.4})$$

If we want self-similar solutions, the terms in brackets in Eq. (A4.4) must be independent of x , i.e. constants. Let us consider the term $\frac{U\sigma}{K} \frac{d\sigma}{dx}$ first. Without loss of generality, we could say that this constant is unity (if it were anything else, σ could be altered so that it is). This results in:

$$\frac{U\sigma}{K} \frac{d\sigma}{dx} = 1 \Leftrightarrow K = \frac{U}{2} \frac{d\sigma^2}{dx} \quad (\text{A4.5})$$

which is discussed in Section 4.3. Before proceeding, we can bring in the model for the eddy diffusivity to discover how the plume grows with x . For long times, K is constant and Eq. (A4.5) gives that $\sigma^2 = 2K \frac{x}{U}$, i.e. we recovered Eq. (4.11). For short times, the diffusivity is proportional to u' and the characteristic length of eddies inside the plume. This is σ , i.e. the width of the plume itself, since the plume cannot be mixed by eddies greater than its size. So for short times, $K = u'\sigma$, which gives $\sigma = \frac{u'}{U} x$, i.e. we recovered Eq. (4.14). We also determined how the width of the plume grows with x : for long times, $\sigma \sim x^{1/2}$, while for short times $\sigma \sim x$.

The second requirement for self-similar solutions is that the term $\frac{U\sigma^2}{K\Phi_0} \frac{d\Phi_0}{dx}$ be independent of x . We can relate $d\Phi_0/dx$ to $d\sigma/dx$ by examining the overall conservation of mass of our (inert) pollutant. Integrating across any section of the plume gives

$$\int_{-\infty}^{\infty} \bar{\phi} dz = Q/UH \Leftrightarrow \Phi_0 \sigma \int_{-\infty}^{\infty} f(\eta) d\eta = Q/UH \quad (\text{A4.6})$$

Denote the integral above by I . Since it is a function of η only, it is independent of x . Therefore, $\Phi_0 \sigma$ is a constant, which gives that $\frac{1}{\Phi_0} \frac{d\Phi_0}{dx} = -\frac{1}{\sigma} \frac{d\sigma}{dx}$. Hence, $\frac{U\sigma^2}{K\Phi_0} \frac{d\Phi_0}{dx} = -\frac{U\sigma^2}{K\sigma} \frac{d\sigma}{dx} = -1$.

Therefore, Eq. (A4.4) becomes

$$\frac{d^2 f}{d\eta^2} + \eta \frac{df}{d\eta} + f = 0 \quad (\text{A4.7})$$

with boundary conditions

$$f(0) = 1, \quad f'(0) = 0 \quad (\text{A4.8})$$

and the solution should obey $f(\pm\infty) \rightarrow 0$. It is very easy to confirm that a function satisfying all the above is

$$f(\eta) = \exp(-\eta^2/2) \quad (\text{A4.9})$$

(This can also be derived by solving Eq. A4.7 directly). From Eq. (A4.6), we also found that $\Phi_0 \sim \sigma^{-1}$, i.e. the characteristic scale of the pollutant concentration decreases as $x^{-1/2}$ for long times and as x^{-1} for short times.

The problem is almost solved now. The mean concentration is given by

$$\bar{\phi} = \frac{1}{I} \frac{Q/H}{U\sigma} f(\eta) \quad (\text{A4.10})$$

Using Eq. (A4.9) and the fact that $I = \int_{-\infty}^{\infty} e^{-\eta^2/2} d\eta = 1/\sqrt{2\pi}$, Eq. (A4.10) gives the final result for the concentration:

$$\bar{\phi} = \frac{Q/H}{\sqrt{2\pi}U\sigma} \exp\left(-\frac{z^2}{2\sigma^2}\right) \quad (\text{A4.10})$$

This is identical to Eq. (4.20) for one-dimensional spreading in the z -direction (without ground effect).

We have shown here how the concept of self-similarity and the overall conservation of pollutant mass gave us the scaling of characteristic width and centerline concentration with downwind distance. The approach can be extended to more dimensions. For example, for two dimensional spreading, put $\bar{\phi} = \Phi_0 f(\eta)g(\zeta)$ with $\eta = z/\sigma_z$ and $\zeta = y/\sigma_y$. Repeating the procedure to seek self-similar solutions will result in Eq. (4.16).

5. Turbulent reacting flows and stochastic simulations

5.1 Fast and slow chemistry

Turbulence time and length scales

The turbulence has a wide range of scales. If the rms velocity fluctuation is u' and the large eddy length scale L_{turb} , the large eddy turnover time, T_{turb} , is given by

$$T_{turb} = \frac{L_{turb}}{u'} \quad (5.1)$$

and the eddies at the Kolmogorov level have a time and length scale of

$$T_K = T_{turb} \text{Re}_t^{-1/2} \quad (5.2)$$

$$\eta_K = L_{turb} \text{Re}_t^{-3/4} \quad (5.3)$$

where

$$\text{Re}_t = \frac{u' L_{turb}}{\mu / \rho} \quad (5.4)$$

is the Reynolds number of the turbulence. For a typical location low in the atmospheric boundary layer, we may have that $u' = 1$ m/s, $L_{turb} = 100$ m, and for air $\mu/\rho = 1.5 \times 10^{-5}$ m²/s. These values give $T_{turb} = 100$ s, $\text{Re}_t = 6.7 \times 10^6$, and hence $T_K = 0.04$ s and $\eta_K = 0.8$ mm. So there is a very wide range of time and length scales in typical flows in the environment.

Chemical timescales – the Damköhler number

From the presentation of chemistry in Chapter 2, it is evident that the rate of the reaction is determined by the amount of reactant and by the reaction rate constant k . The governing equation for a scalar (Eq. 3.9) has terms due to the fluid mechanics (advection, turbulent diffusion, molecular diffusion) and due to the chemistry. Therefore the net rate of change of the scalar will depend on both phenomena. Now, added to this that the various terms in Eq. (3.9) have different scaling even without chemistry (large-eddy scaling for the mean and turbulent transport, small-eddy scaling for the molecular diffusion), we see that the relative effect of the turbulence on the reaction will depend on the ratio of turbulent to chemical timescales, called the *Damköhler number*. We usually define two such ratios, one using the large-eddy timescale and another using Kolmogorov timescale:

$$Da_1 = \frac{T_{turb}}{T_{chem}}, \quad Da_2 = \frac{T_K}{T_{chem}} = Da_1 \text{Re}_t^{-1/2} \quad (5.5)$$

We do this because the chemical reaction occurs at the small scales, where the reactants mix at a molecular level, but we are also interested to know how the reactants get together in the first place, and this is determined by the large scales. These complications are typical of turbulent flows. It is not just a coincidence that turbulent reacting flows are considered one of the most difficult problems in the whole of turbulence and fluid mechanics fields!

A way to define the chemistry timescale is illustrated by the following example. Take the reaction $\text{NO} + \text{O}_3 \rightarrow \text{NO}_2 + \text{O}_2$. The consumption rate of $[\text{NO}]$ from this reaction is $d[\text{NO}]/dt = -k[\text{NO}][\text{O}_3]$. Treating $[\text{O}_3]$ to be constant, we obtain $d[\text{NO}]/dt = -A[\text{NO}]$, which gives an exponential decay with timescale defined as $1/A$. Typical concentrations of NO and O_3 in a typical early morning are 3×10^{-9} and 1.5×10^{-9} kmol/m^3 respectively and the rate constant is $k = 1 \times 10^7$ $\text{m}^3/\text{kmol/s}$. Hence, for this reaction and for these concentrations, $T_{chem} = 66.7$ s. This is a fast reaction for atmospheric chemistry; others are many orders of magnitude slower. The definition of chemistry timescales becomes more complicated if there are many elementary reactions that consume or produce a particular species, as is almost always the case. This makes matters very difficult, as far as theoretical predictions go.

Simplifications

Fast chemistry ($Da_2 \gg 1$):

If the chemistry is considered to be very fast compared to all fluid mechanics scales, then the rate of chemical reaction follows the rate at which reactants are being mixed. This is the basis of many models, such as the “eddy break up”, the “mixed is burned” and the “eddy dissipation concept” (Peters, 2000). All these have been used extensively in the combustion literature, where indeed the chemistry is usually fast compared to mixing times, e.g. inside engines.

The situation is less clear concerning environmental flows. There, the large eddy time scales are longer than in engines, but the Re_t is higher, and hence the Kolmogorov time scale may not be very different. The chemistry, on the other hand, is much slower in the atmosphere than in a flame. This makes the fast chemistry limit invalid for atmospheric pollutants. Hence, the well-proven techniques that are embodied in commercial CFD codes, usually tuned to combustion or other chemical engineering problems, may not be always applicable to environmental reacting flows.

Slow chemistry ($Da_1 \ll 1$):

At the other extreme, if the mixing times are much faster than the chemistry, we may consider that the reactants are well-mixed, i.e. that the pollutants are uniformly distributed in space, at least over a scale comparable to L_{turb} . This means that the degree of scalar fluctuation is small, which enables us to neglect the correlation $\overline{\phi'_1 \phi'_2}$. This then allows the straightforward application of Eq. (3.19) without any need to provide closure for the turbulence effects on the reaction, which is calculated simply using the mean concentrations (an assumption sometimes called “laminar chemistry”).

This assumption is very often introduced in air quality models that are currently used for monitoring and certification purposes. However, as these models progressively look into finer and finer length and time scales (e.g. the NO emitted from cars in street canyons), the assumption of well-mixed reactants becomes invalid. See Example 5.2 for more discussion on this.

Intermediate ($Da_2 < 1 < Da_1$):

This is the most difficult, and the most relevant, situation, which is currently under intensive research. No simple theory exists for this regime. One very useful and insightful technique is to calculate the joint pdf of the scalars by numerical means, and this is introduced next.

5.2 Monte Carlo simulations

Fundamentals of Monte Carlo techniques

In Monte Carlo techniques, a large number of events are sampled from the possible sample space and their evolution is tracked. Averages formed over many such “trajectories” give the behaviour, in a statistical sense, of the whole system. Other, perhaps more accurate, names for this technique include “*stochastic modelling*” or “*stochastic simulation*”. Monte Carlo techniques are used for an immense variety of topics (e.g. statistical mechanics, molecular dynamics, chemistry, turbulence, stock market risk analysis). The following examples aim to clarify the technique.

Example 1 of Monte Carlo simulation

Assume we have a die. Each time we roll it, we note the result (1 to 6) which we call x . Then, we use this number to initiate the following sequence of events: (i) calculate $y(x) = (x/6)^2 + \sin(x/6) + x \exp(-x/6)$; (ii) if the result is less than 0.5, it is “YES”; (iii) if the result is greater than 0.5, it is “NO”. We want to calculate the probability of “YES”.

Clearly, an analytical approach is extremely difficult (but not impossible for this particular example). The Monte Carlo approach is the following: (i) sample N random numbers from a uniform distribution between 1 and 6; (ii) calculate $y(x)$ for each of these N samples; (iii) for each of the resulting $y(x)$, determine if it gives “YES” or “NO”; (iv) count the number N_{YES} of events that were “YES”. The probability of getting “YES” is then simply N_{YES}/N .

All that is needed is a computer and a random number generator (and there are plenty of library codes in Fortran, C, or in Matlab for that).

Example 2 of Monte Carlo simulation

Assume you have £100.00 that you want to invest in 10 different stock market companies, S_1, S_2, \dots, S_{10} , each of which today costs $A=£1.00$. History suggests that the probability of S_1 rising tomorrow by a fraction f_1 (i.e. the value tomorrow is equal to $(1+f_1)A$) is given by a normal distribution with mean $\mu_1=0.01$ and rms $\sigma_1=0.1$. So, on average, the price of S_1 tomorrow will be £1.01, but it could be anywhere between $(1.01-3\cdot 0.1)$ and $(1.01+3\cdot 0.1)$ (to within 99%). Similar historical data are assumed to apply to all our equities. There could also be various restrictions, for example: if it happens that S_1 becomes greater than £1.50, then S_3 will fall by 10%, etc. We want to calculate the spread in the possible worth of our investment portfolio after one month.

A Monte Carlo simulation would be to simulate a very large number of possible “scenarios” and then evaluate the worth of the portfolio at the end of the month. The steps would be: (i) pick randomly a value for each f_i (i.e. for each stock), each according to its own distribution (assumed known from historical data). Hence you get the new price of each stock S_i . (ii) Enforce the various restrictions (e.g. change the S_i ’s accordingly). (iii) Continue for the next day. After doing the simulation for 30 days, you get the value of your investment for this particular realization. (iv) Repeat steps (i) to (iii) for N (some thousands) of these scenarios.

At the end of the simulation, we have N possibilities, each with a different total worth of our investment. These define the pdf of our investment value, which helps answer questions like “what is the probability that we will lose 10% of our money” or “what is the probability that we will gain 20%” etc.

Warning: this is a hypothetical example: DON’T TRY IT – no responsibility is borne by the lecturer if you lose your money!

Monte Carlo simulation in turbulent reacting flows

These ideas are used to great advantage in turbulent reacting flows. The reason is that since the chemistry is non-linear, the effect of the scalar fluctuations is not analytically tractable (i.e. correlations develop, Eq. 3.19) and so keeping track of various “scenarios” of scalar values and averaging over all of them, allows us to estimate the evolution, in the mean, of our system.

Assume we have a domain with homogeneous isotropic turbulence with K scalars that participate in chemical reactions. For this spatially uniform system, the governing equation for the mean scalar becomes:

$$\frac{\partial \overline{\phi_i}}{\partial t} = \overline{\dot{w}_i} \quad (5.6)$$

(we need not specify in more detail the reaction rate at this stage). The mean convection and diffusion terms disappeared due to spatial uniformity. At time $t=0$, each scalar i has concentration ϕ_i that is distributed according to a probability density function, say a Gaussian with mean $\overline{\phi_i}$ and rms σ_i and there are no correlations between the species (i.e. $\overline{\phi_i \phi_j} = 0$). We want to calculate the subsequent evolution of the system. Clearly, we need a model for $\overline{\dot{w}_i}$, but no such model is available and hence the direct solution of Eq. (5.6) is impossible.

Consider, however, the following surrogate to the real system: let the fluid be composed of a large number of individual “fluid particles”. Each of these fluid particles has a random composition such that when we average over all particles, we get the right mean and rms of the fluid composition (i.e. the known, initial $\overline{\phi_i}$ and σ_i). The basic steps in a Monte Carlo simulation are the following:

- (i) For each particle, pick a random composition from a Gaussian with mean $\overline{\phi_i}$ and rms σ_i (the index i refers to the i -th species).
- (ii) Calculate the reaction rates \dot{w}_i for this fluid particle for all scalars i .
- (iii) Solve
$$\frac{\partial \phi_i}{\partial t} = -\frac{\phi_i - \overline{\phi_i}}{T_{turb}} + \dot{w}_i \quad (5.7)$$

for each scalar and for each particle from $t=t_0$ until time $t=t_0+\Delta t$. Equation (5.7) is a modeled instantaneous equation for the conservation of the scalar ϕ_i inside the fluid particle (i.e. the corresponding Eq. 3.8 for the fluid particle). The first term in the r.h.s. is a modeled turbulent diffusion term, while the second term is the chemical reaction.

- (iv) We now have the new composition for each of the particles. Evaluate the new mean $\overline{\phi_i}$ (i.e. perform an average over all particles) for all scalars.
- (v) Repeat steps (ii) to (iv) until we reach the end of the time domain we are interested in.

This sequence of steps is a very simplified version of the proper Monte Carlo approach to turbulent reacting flows, but it may serve to illustrate the basic concept. In essence, we do not look at the fluid as a whole, but as composed of individual stochastic fluid elements. Each of these, undergoes mixing with its neighbours (the term $-(\phi_i - \overline{\phi_i})/T_{turb}$ in Eq. 5.7) and chemical reactions in itself

(the term \dot{w}_i). Hence, by looking at a large number of these stochastic particles, we get a picture of the whole system. A more rigorous treatment can be found in Pope (2000).

Once the simulation has been performed, the joint pdf of the scalars is known and the final mean composition has been calculated. Hence, the Monte Carlo simulation replaces the need to solve Eq. (5.6) by the need to solve the more straightforward Eq. (5.7). Chemistries to any complexity can be handled, but the computational cost is high because Eq. (5.7) has to be solved for thousands of particles to be able to get accurate statistics.

Stochastic simulation techniques such as the one outlined above are used in a variety of other environmental fluid mechanics problems, for example the dispersion of solid particles in the wind, the diffusion of contaminated water in aquifers, and the propagation of radio waves in the atmosphere. They also find application in chemical engineering and in combustion inside engines and burners.

5.3 The meandering plume

Basic idea

A model for the “meandering plume” or “looping plume” (Fig. 4.6) is to consider the dispersion of a regular plume, but with its axis moving randomly (Fig. 5.1). This could be caused, for example, by strong short-lived gusts of wind. We assume that the concentration at every point is given as an average over all possible plume motions. This is called also the “flapping model” (Csanady, 1973) and is an excellent candidate for a Monte Carlo simulation.

For simplicity of presentation, let us assume that meandering occurs only in the horizontal direction and that the plume is well mixed in the z -direction. The horizontal profile, relative to the centre of the plume, is given by Eq. (4.20). Assume now that the centre of the plume moves horizontally a distance Y , where Y obeys a Gaussian with zero mean and standard deviation Y_{RMS} . A Monte Carlo procedure for describing this plume would be composed of the following steps:

- (i) Sample a random number for Y from a Gaussian with zero mean and the given Y_{RMS} .
- (ii) In Eq. (4.20), use $y-Y$ instead of y and hence evaluate the concentration $\phi(y)$, i.e.

$$\phi(y) = \frac{Q}{UH} \frac{1}{\sqrt{2\pi}\sigma_y} \exp\left(-\frac{(y-Y)^2}{2\sigma_y^2}\right)$$

- (iii) Repeat (i)-(ii) for the N different values sampled for Y , where N is of the order of 1000.
- (iv) The required mean concentration is $\bar{\phi}(y) = \frac{1}{N} \sum \phi(y)$.

A computer code to achieve the simulation needs only a random number generator, the rest being very straightforward. The resulting profile of the mean concentration for all y is shown in Fig. 5.2 for different values of the ratio Y_{RMS}/σ_y . Note the “broadening effect” caused by the large-scale motion, which results in lower centreline concentrations, but a larger plume width. The procedure can be very easily generalized to two-dimensional meandering. If there were no meandering, the centreline concentration would be $\bar{\phi}(0) = Q/(UH\sqrt{2\pi}\sigma_y)$. With meandering with $Y_{RMS}/\sigma_y=5$, the centreline concentration is $0.2Q/(UH\sqrt{2\pi}\sigma_y)$ (from Fig. 5.2), which shows that meandering causes a significant reduction in the mean dosage of pollutant received.

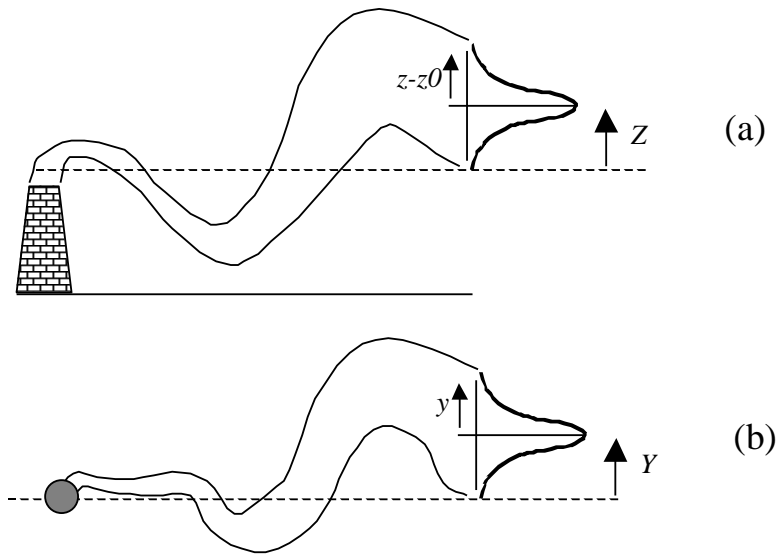

Figure 5.1 The meandering plume. (a) View from the side. (b) View from above.

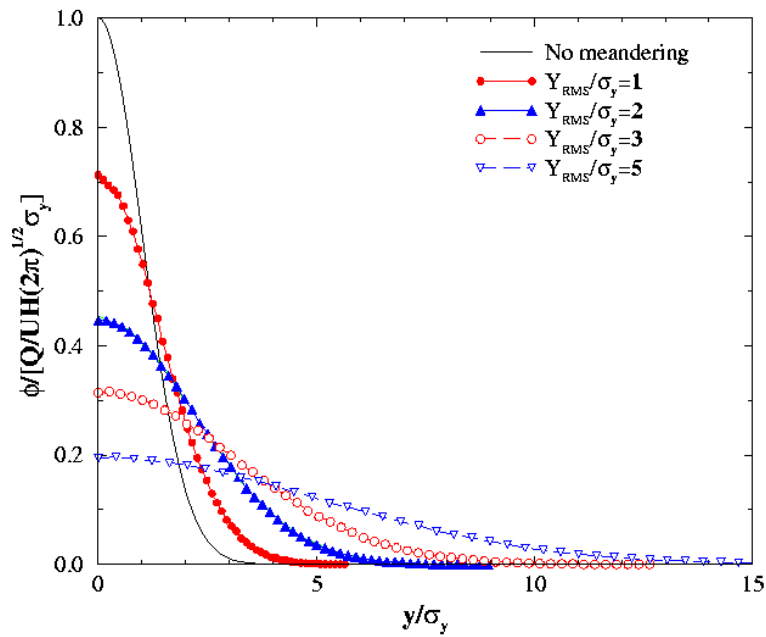

Figure 5.2 The mean concentration across a meandering plume for different values of Y_{RMS}/σ_y .

Comments

If we wanted to approach this problem analytically, the mean concentration at y would be given by:

$$\bar{\phi}(y) = \int_{-\infty}^{\infty} \phi(y, Y) P(Y) dY = Q / (UH \sqrt{2\pi} \sigma_y) \int_{-\infty}^{\infty} \exp\left(-\frac{(y - Y)^2}{2\sigma_y^2}\right) P(Y) dY \quad (5.8)$$

This is quite difficult to evaluate in closed form and if at all, it can be done only for simple forms of the $P(Y)$, the pdf of Y . It can be shown that for a Gaussian $P(Y)$, $\bar{\phi}(y)$ is given by an expression identical to Eq. (4.20), but with an effective dispersion coefficient

$$\sigma_{y,meand}^2 = \sigma_y^2 + Y_{RMS}^2 \quad (5.9)$$

This is typical of random, uncorrelated motions: the overall variance due to the action of two phenomena (meandering, smaller-scale turbulent diffusion) is the sum of the variances due to each phenomenon alone. (This concept is also used in experimental error estimation.) The basic assumption behind the flapping model presented previously is that the turbulent diffusion motions resulting in Eq. (4.20) are uncorrelated from the large-scale motions causing the meandering. However, in real atmospheric turbulence, the scales causing mixing of the plume are not fully independent from the motions causing the meandering. Hence, the discussion above should be seen as only an approximation to a real plume exposed to sudden, strong, cross winds.

Equation (5.8) cannot be easily evaluated analytically for other shapes of the pdf of Y . However, the stochastic simulation does not have this restriction and it also gives access to the full pdf of ϕ , which is very useful for predicting the fluctuations of pollutant at a particular point.

5.4 Worked examples

Example 5.1

On a particular day, the air above a city is completely still. A box model (Section 4.1) is here extended to account for small-scale turbulent fluctuations in the concentrations that are a function of time. Assume that there are no emissions and that the pollutant is inert with homogeneous mean concentrations in all directions, but that there are significant fluctuations at $t=0$. Hence, simplify and solve Eq. (3.16). The turbulence lengthscale is $L_{turb}=50$ m and the turbulence velocity is $u' = 0.1$ m/s. Calculate the rms after 5 min as a fraction of the initial rms σ_0 .

Solution

When there are no spatial inhomogeneities, Eq. (3.12) becomes

$$\frac{\partial \bar{\phi}}{\partial t} + \bar{u}_j \frac{\partial \bar{\phi}}{\partial x_j} = \frac{\partial}{\partial x_j} \left[D_T \frac{\partial \bar{\phi}}{\partial x_j} \right] + \bar{w} \Leftrightarrow \frac{d\bar{\phi}}{dt} = 0 \Leftrightarrow \bar{\phi}(x, y, z, t) = const, \text{ as expected. The equation}$$

for the variance (Eq. 3.16, using Eq. 3.17) becomes: $\frac{d\sigma^2}{dt} = -2 \frac{u'}{L_{turb}} \sigma^2$. Integrating this equation

gives: $\sigma^2 = \sigma_0^2 \exp(-2t/T_{turb})$, with $T_{turb} = L_{turb}/u'$. This is an exponential decay to zero from the initial value of σ_0 . This shows that the inert scalar fluctuations will have decayed to $1/e$ their initial value over one half turbulence timescale and that they will have essentially disappeared after three turbulence times. For the conditions given, $T_{turb}=500$ s, and hence $\sigma/\sigma_0=0.3$. Note the quick disappearance of the fluctuations in atmospheric turbulence, e.g. of the order of minutes. This is consistent with everyday experience.

Example 5.2

Repeat Ex. 5.1, but now assume (a) that the pollutant is photolysed at a rate $-Jc$, where J is a constant and c the pollutant concentration; (b) that the pollutant is destroyed at a rate $-Jc^2$.

Solution

In this Example, the mean concentration is changing with time due to the chemistry and we need to include the fluctuations in the chemical source term.

$$(a) \text{ The governing equation becomes: } \frac{d\bar{c}}{dt} = \bar{\dot{w}} \Leftrightarrow \frac{d\bar{c}}{dt} = -J\bar{c} = -J\bar{c} \Leftrightarrow \bar{c} = \bar{c}(0) \exp(-Jt).$$

The corresponding equation for the reacting scalar variance is now $\frac{d\sigma^2}{dt} = -2\frac{u'}{L_{turb}}\sigma^2 + 2\overline{c'\dot{w}'} = -\frac{2}{T_{turb}}\sigma^2 - 2J\overline{c'c'}$. The solution is easily

obtained as: $\sigma^2 = \sigma_0^2 \exp(-2t/T_{turb}) \exp(-2Jt)$. So now the decay of the fluctuations depends on the turbulence and on the chemistry. If the initial mean concentration is C , an appropriate chemical timescale is C/J . We can then define a Damköhler number as $Da = JT_{turb}/C$. If $C/J \gg T_{turb}$ (i.e. $Da \ll 1$), we have intense turbulence and the fluctuations will have decayed to zero well before the reaction is felt. On the other hand, if $C/J \ll T_{turb}$, the fluctuations decay because the reactant is consumed ($c' \rightarrow 0$) according to the chemical timescale and the turbulence plays little role. This Examples clearly demonstrates the Damköhler number criteria in Section 5.1.

(b) In this case, we have non-linear chemistry and the system of equations becomes:

$$\frac{d\bar{c}}{dt} = \bar{\dot{w}} \Leftrightarrow \frac{d\bar{c}}{dt} = -J\bar{c} \Leftrightarrow \frac{d\bar{c}}{dt} = -J\bar{c}^2 - J\sigma^2$$

$$\frac{d\sigma^2}{dt} = -2\frac{u'}{L_{turb}}\sigma^2 + 2\overline{c'\dot{w}'} \Leftrightarrow \frac{d\sigma^2}{dt} = -\frac{2}{T_{turb}}\sigma^2 - 2J\overline{c'2\bar{c}c'} \Leftrightarrow \frac{d\sigma^2}{dt} = -\sigma^2 \left(\frac{2}{T_{turb}} + 4J\bar{c} \right) - J\overline{c'^3}.$$

($\dot{w} = -Jc^2 \Leftrightarrow \bar{\dot{w}} + \dot{w}' = -J(\bar{c} + c')^2 \Leftrightarrow \bar{\dot{w}} + \dot{w}' = -J(\bar{c}^2 + c'c' + 2\bar{c}c') \Rightarrow \overline{c'\dot{w}'} = -2J\bar{c}\overline{c'^2} - J\overline{c'^3}$). It is evident that we cannot proceed unless we supply a model for the third-order correlation.

This example shows how difficult the combined turbulence-reaction system can become when the chemistry is non-linear. However, it also demonstrates the very useful conclusion that for fast turbulence relative to the reaction ($Da \rightarrow 0$), we can safely assume that the reactants are well-mixed ($\sigma \rightarrow 0$). Virtually all Air Quality Models in practice are based on this assumption, which is used without much thought even if Da is not very small due to the large simplification it offers.

6. Summary and main points

The main objectives of these Notes have been:

- (i) To describe the nature of some common atmospheric pollutants and their chemical evolution.
- (ii) To introduce techniques to describe the statistical nature of scalars and the mixing encountered in turbulent flows.
- (iii) To present the standard approaches currently in use by environmental regulation agencies for predicting the concentration of pollutants above cities or downwind of pollution sources.
- (iv) To emphasize that the present status of modelling of turbulent reacting flows in the environment include significant uncertainties because perfect mixing is usually assumed. This is sometimes improper for non-linear chemistries, such as that of environmental pollution, but it is correct if the chemistry is slow relative to the turbulence.
- (v) To familiarize the student with Monte Carlo simulations because they are an extremely powerful tool when dealing with stochastic phenomena like turbulence.

The most important points in these Notes are the following:

- (i) Sections 2.2 and 2.3, where common pollutants and their chemistry are presented.
- (ii) Equations (3.8) and (3.9) for the instantaneous and mean scalar.
- (iii) The eddy diffusivity and Eq. (3.12).
- (iv) The equation for the variance (3.16) and the model in Eq. (3.17).
- (v) The source term problem (Eq. 3.19).
- (vi) The concept of the probability density function.
- (vii) Equation (3.22), definitions of the mean, rms and variance (Section 3.3).
- (viii) The example in Section 3.3.
- (ix) The box model, Section 4.1
- (x) The Gaussian plume, Eq. (4.16), and the ground concentration, Eqs. (4.18, 4.19).
- (xi) The use of Fig. 4.4 for the dispersion coefficients.
- (xii) The difference between fast and slow chemistry (Section 5.1).
- (xiii) The concept of the Monte Carlo simulation (Section 5.2).

5R18: Environmental Fluid Mechanics

Part II: Dispersion of Pollution in the Atmospheric Environment

DATA CARD

Transport equation for the mean of the reactive scalar ϕ :

$$\frac{\partial \bar{\phi}}{\partial t} + \bar{u}_j \frac{\partial \bar{\phi}}{\partial x_j} = \frac{\partial}{\partial x_j} \left(K \frac{\partial \bar{\phi}}{\partial x_j} \right) + \bar{w}$$

Transport equation for the variance of the reactive scalar ϕ :

$$\frac{\partial g}{\partial t} + \bar{u}_j \frac{\partial g}{\partial x_j} = \frac{\partial}{\partial x_j} \left(K \frac{\partial g}{\partial x_j} \right) + 2K \left(\frac{\partial \bar{\phi}}{\partial x_j} \right)^2 - \frac{2}{T_{turb}} g + 2\overline{\phi'w'}$$

Mean concentration of pollutant after instantaneous release of Q kg at $t=0$:

$$\bar{\phi}(x, y, z, t) = \frac{Q}{8(\pi)^{3/2} (K_x K_y K_z)^{1/2}} \exp \left[-\frac{1}{4t} \left(\frac{(x-x_0)^2}{K_x} + \frac{(y-y_0)^2}{K_y} + \frac{(z-z_0)^2}{K_z} \right) \right]$$

Gaussian plume spreading in two dimensions from a source at $(0,0,z_0)$ emitting Q kg/s:

$$\bar{\phi}(x, y, z) = \frac{Q}{2\pi U \sigma_y \sigma_z} \exp \left[-\left(\frac{y^2}{2\sigma_y^2} + \frac{(z-z_0)^2}{2\sigma_z^2} \right) \right]$$

One-dimensional spreading from line source emitting Q/L kg/s/m :

$$\bar{\phi}(x, y) = \frac{Q}{UL} \frac{1}{\sqrt{2\pi}\sigma_y} \exp \left(-\frac{y^2}{2\sigma_y^2} \right)$$

Relationship between eddy diffusivity and dispersion coefficient:

$$\sigma^2 = 2 \frac{x}{U} K$$

Stability categories and empirical data on dispersion coefficients:

A to F refer progressively from the very unstable to the very stable conditions, with D the neutral.

Wind speed at 10 m high (m/s)	Day			Night	
	Solar intensity			Overcast	Clear
	Strong	Moderate	Slight		
0-2	A	A-B	B	-	-
2-3	A-B	B	C	E	F
3-5	B	B-C	C	D	E
5-6	C	C-D	D	D	D
> 6	C	D	D	D	D

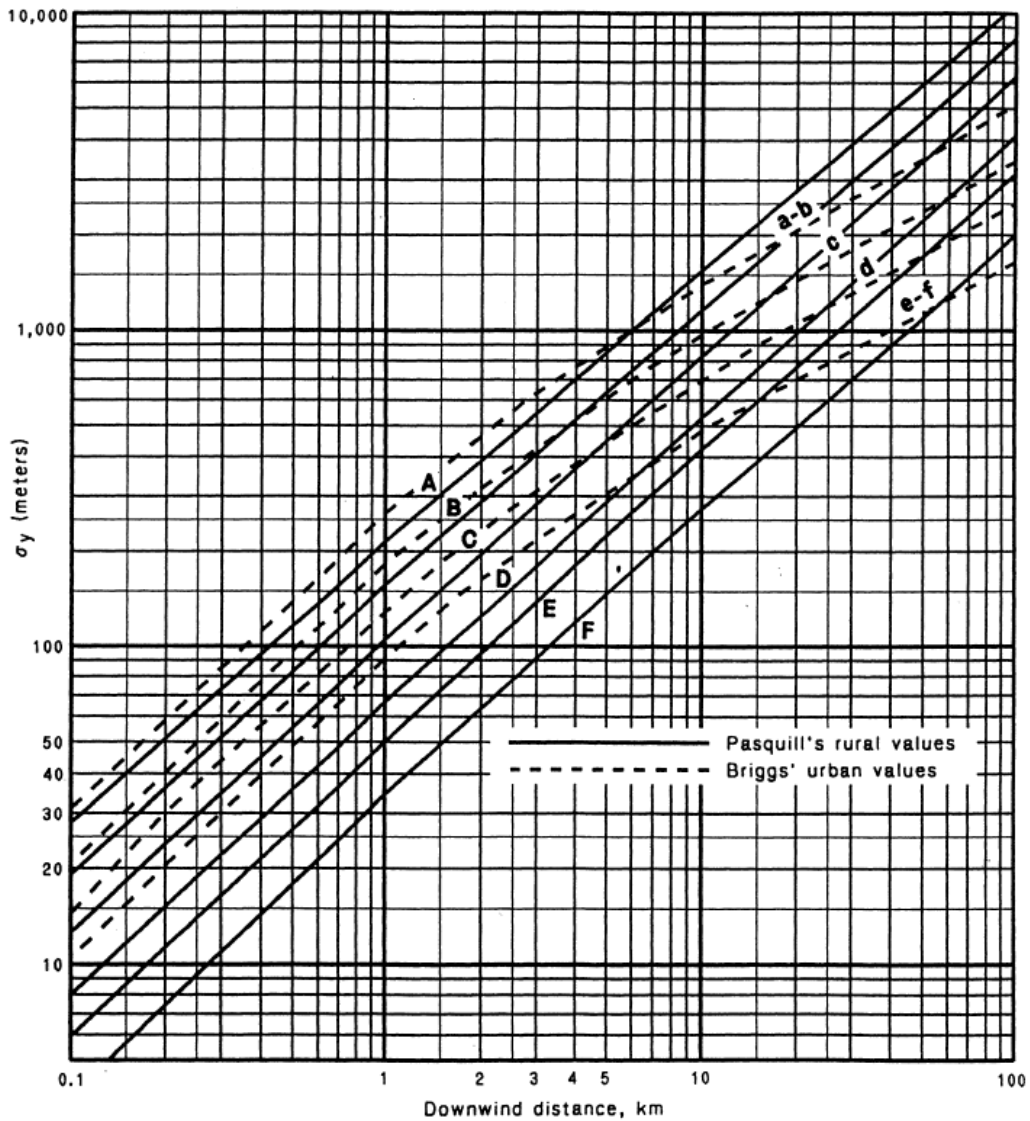

Horizontal

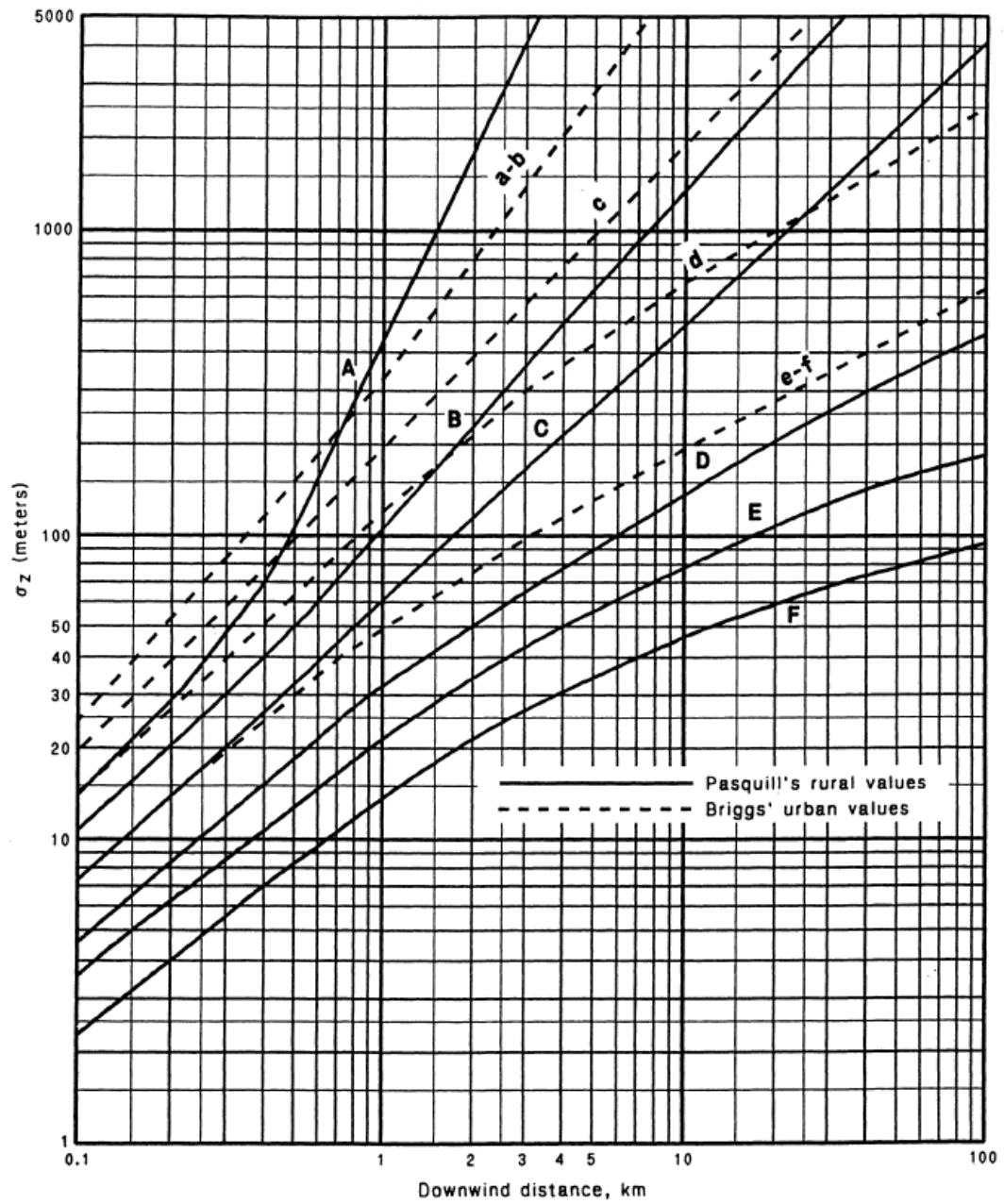

Vertical